

Uhing Lineartriebe[®]
Uhing Linear Drives[®]

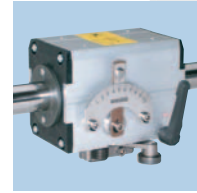

Rollringgetriebe
Rolling Ring Drives



Zubehör
Accessories



Wälzmutter
Linear Drive Nut



Zahnriemenantriebe
Timing Belt Drive

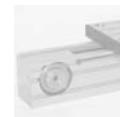

Klemm- und Spannelemente
Clamping Systems



Uhing *Measuring* System[®]



Uhing *Motion* Drive[®]

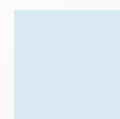

Joachim Uhing GmbH & Co. KG - the originator of the Rolling Ring Principle - successful since 1950. Our worldwide network of agencies guarantees a reliable service on the spot.

More about us at: www.uhing.com

The Uhing Rolling Ring Principle

Rolling Ring Drives are non-positive drives which convert the constant rotation of a plain round shaft into reciprocating motion. They operate like nuts on a threaded bar, however the pitch both left-hand and right-hand can be fine-tuned or set to zero.

This effect is achieved by using ball bearing based Rolling Rings which are designed to tilt on the shaft, their specially crowned running surfaces being pressed against the shaft as it rotates.

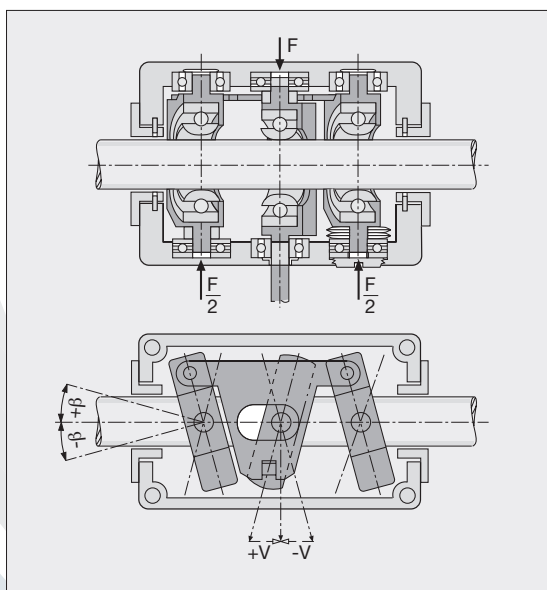

Summary of contents	Page
The Uhing Rolling Ring Principle	2
Applicational areas	3 - 6
Find your suitable Rolling Ring Drive	7
Dimensions and technical details	8 - 16
Types RG Shaft Ø 15, 20 and 22 mm	8 - 9
Types RG Shaft Ø 30 and 40 mm	10 - 11
Types RG Shaft Ø 50, 60 and 80 mm	12 - 13
Types RGK Shaft Ø 15, 20 and 22 mm	14 - 15
Types KI, AKI	16
Product survey and ordering information	17
Features	18 - 19
Technical basics	20 - 26
Selection	20 - 23
1. Formulae and related units	20
2. Preselection	20
3. Side thrust	21
4. Shaft speed	21
5. Shaft drive	22
6. Winding applications	22
7. Calculation of the operational life	23
Operational guide	24-26
1. Shaft material	24
2. Shaft rotation	24
3. Reversal	24
4. Pitch setting	25
5. Separately carried additional loads	25
6. Vertical applications	25
7. Stopping on a rotating shaft	26
8. Traversing characteristics	26
9. Synchronisation of processes	26
10. Operating temperature	26
11. Maintenance	26
Uhing agents	www.uhing.com

Applicational areas

Range of application for Rolling Ring Drives

- Winding
- Drives
- Surface treatment
- Measuring and testing
- Materials handling
- Packaging
- Converting
- Tyre manufacture
- Feeds
- Positioning drives
- Power amplifiers (servo functions)
- Traverse drives for speeds up to 4.2 m/sec.
- Drives for synchronous cutting machines
- Sequential feed drives
- Special machines

Operational areas

Industrial Area

- Automation
- Automobile
- Baking machinery
- Wire + Cable industry
- Flat glass/mirrors
- Braiding machinery
- Foil
- Hollow glass ware
- Varnishing
- Food industry
- Paper/cardboard
- Tyres
- Steel
- Textile
- Packaging
- Pharmacy

The main advantages of the Uhing Rolling Ring Principle:

- Automatic reciprocating motion*
- Variable adjustment of traverse speed up to 4,2 m/sec. max., also different for both directions*
- Variable adjustment of traverse length
- High dynamics at the reversal points
- Free-movement lever
- Low operating costs

* at constant speed and direction of shaft rotation

Function

- Coating
- Feeding
- Manipulating
- Measuring/testing
- Opening/closing
- Positioning
- Cleaning
- Cutting/parting
- Spraying
- Sequencing
- Linking
- Packing
- Spreading
- Winding
- Mixing

Applicational areas

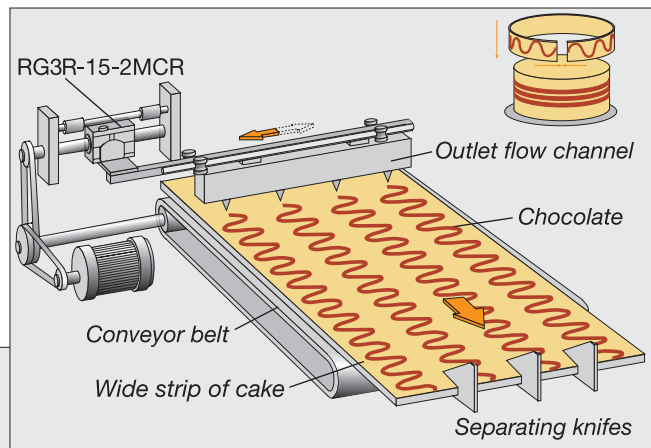

Production of tarts



Reversal depending on counterforce

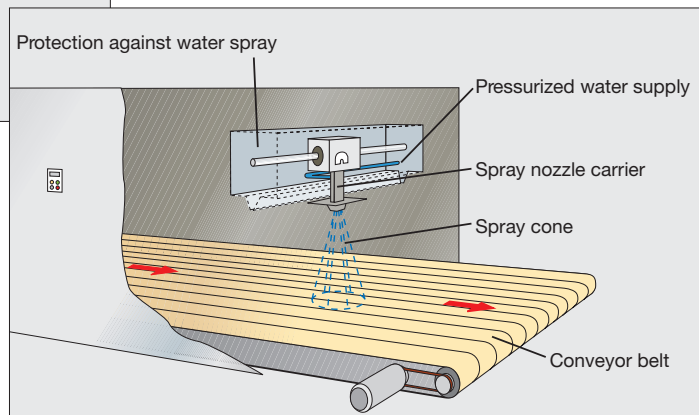

Cleaning with pressurised water for conveyor belt

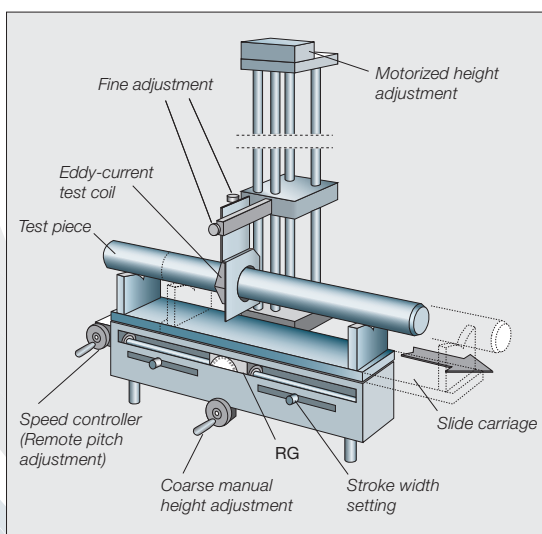

Eddy-current test slide

Converting-cut to final dimension

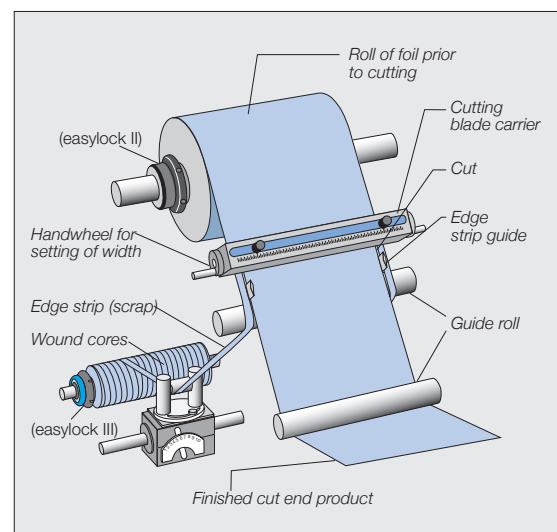

Applicational areas

Winder "Moving Spool"-type

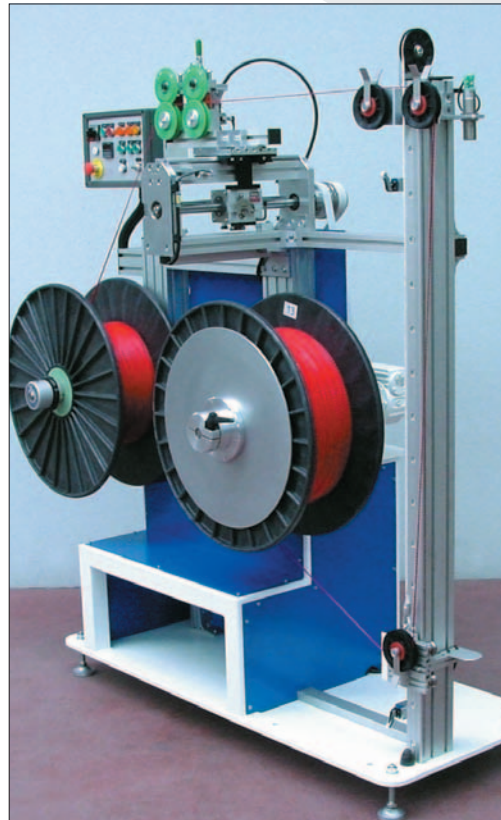
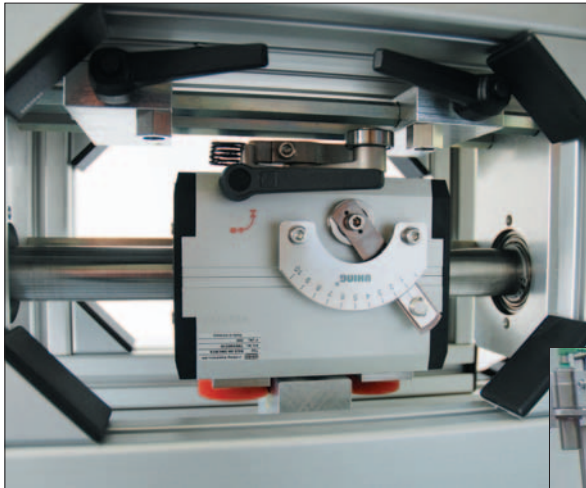
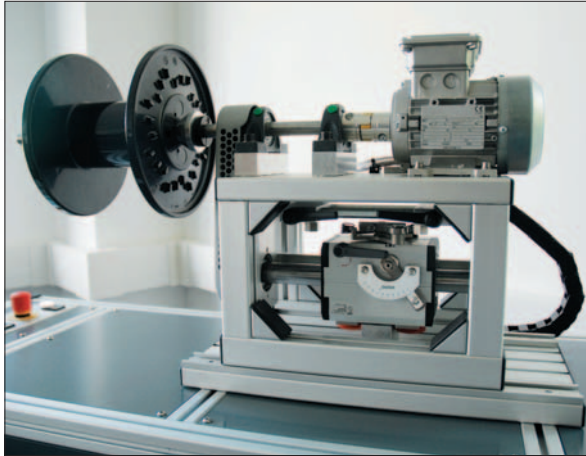

Double winder

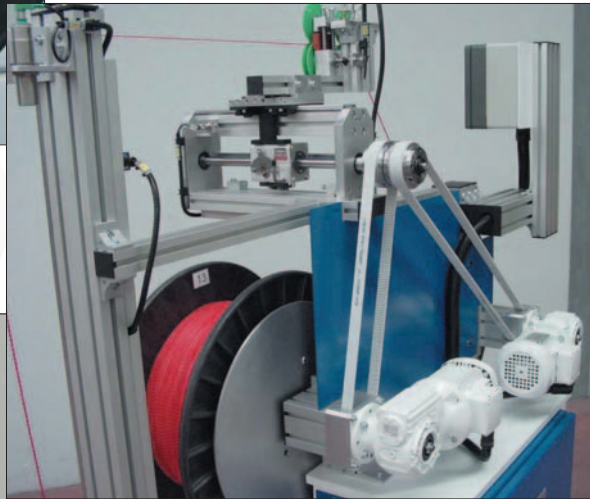

Uhing Measuring System

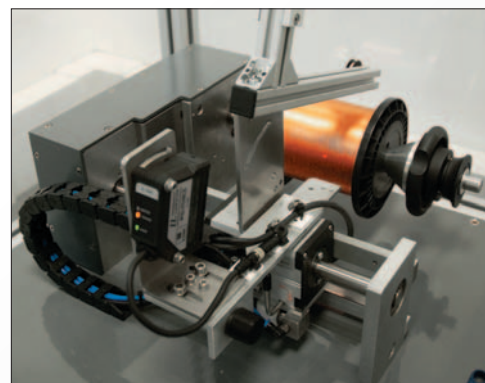

Applicational areas

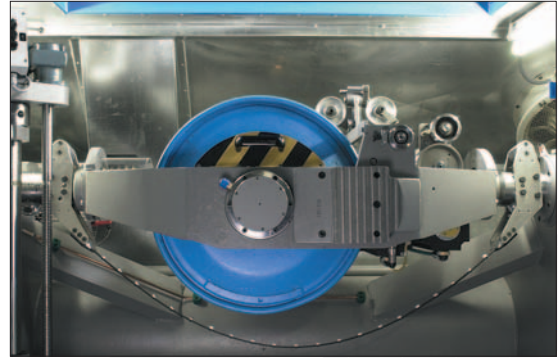

Buncher

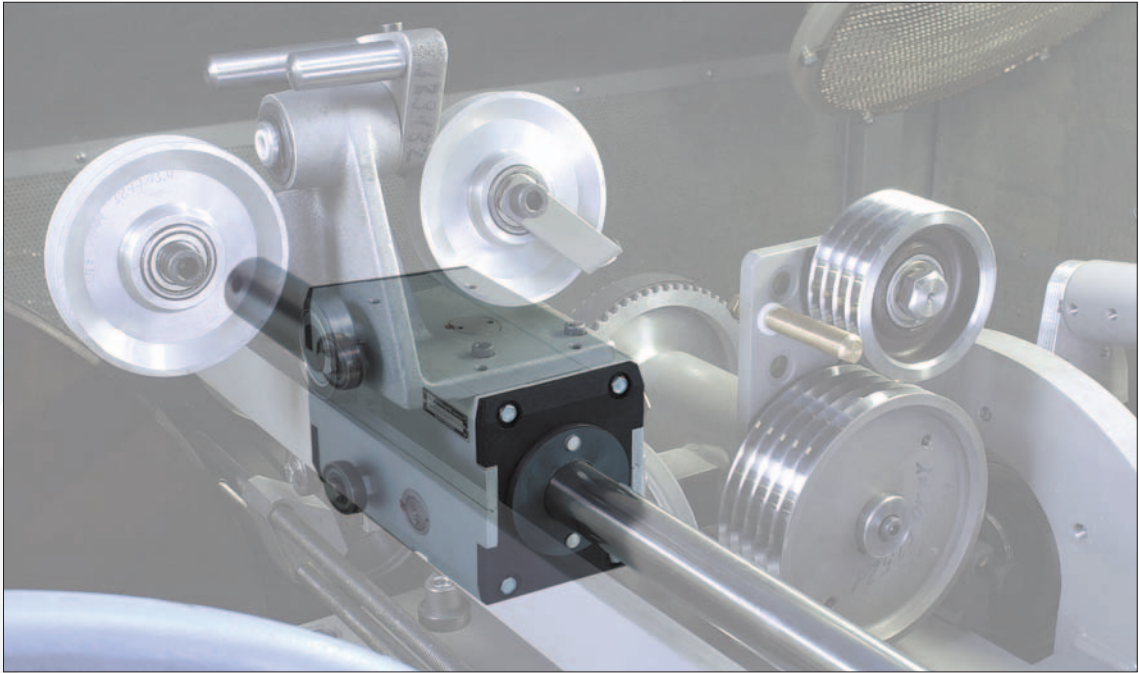

Application at -30°C
in the Antarctic

Photo Antarctic:
© by Paul Anker/
British Antarctic
Survey



Find your suitable rolling ring drive

Shaft diameter d(mm)	Max. side thrust F_{RG} (N)	Speed max. v^* (m/sec)	Types	Page
15	30	0.30	KI3L/R-15-6 MCR	16
15	90	0.30	RGK3-15-0	14
15	110	0.30	RG3L/R-15-2MCRF	8
15	220	0.30	RG4L/R-15-2MCRF	8
20	130	0.30	RGK3-20-1	14
20	160	0.30	RG3L/R-20-2MCRF	8
20	320	0.30	RG4L/R-20-2MCRF	8
22	130	0.30	RGK3-22-1	14
22	160	0.30	RG3L/R-22-2MCRF	8
22	320	0.30	RG4L/R-22-2MCRF	8
30	260	0.40	RG3L/R-30-2MCRF	10
30	520	0.40	RG4L/R-30-2MCRF	10
40	420	0.40	RG3L/R-40-2MCRF	10
40	840	0.40	RG4L/R-40-2MCRF	10
50	700	0.25	RG3L/R-50-OMCR	12
50	1400	0.25	RG4L/R-50-OMCR	12
60	1000	0.25	RG3L/R-60-OMCR	12
60	2000	0.25	RG4L/R-60-OMCR	12
80	1800	0.25	RG3L/R-80-OMCR	12
80	3600	0.25	RG4L/R-80-OMCR	12

* = With standard instantaneous reversal

Example ARG3R-30-2 MCRF

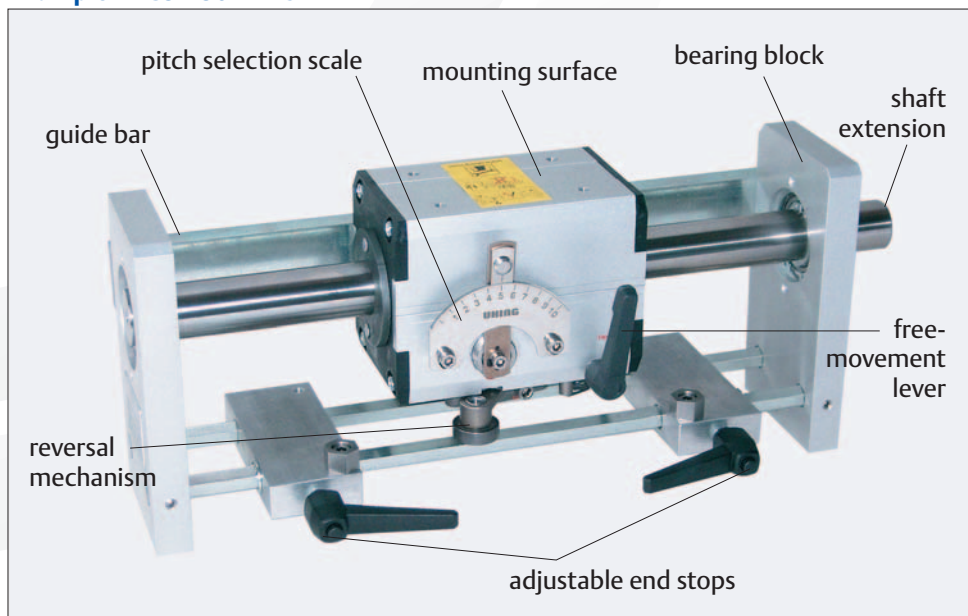

Dimensions and technical details

Uhing Rolling Ring Drive Types RG and ARG

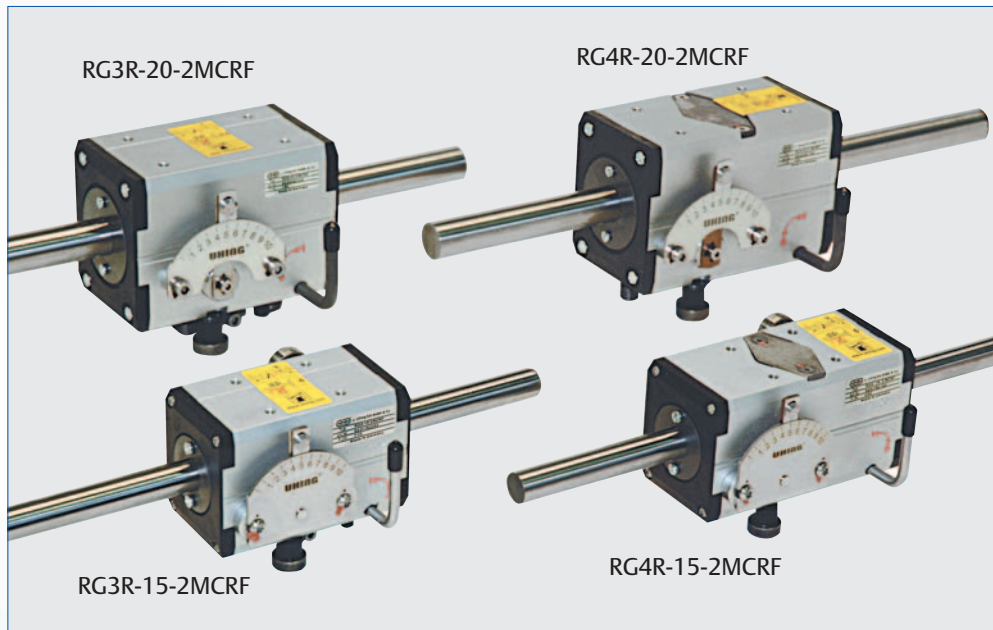

Dimensions for RG Types (mm)															
Types	Weight (kg)	a	b	Ødh6	e	f	g	l	n	o	p	tmax.	m	x	
RG3L -15-2 MCRF	0,71	102	63	15	36	32	M5	25	24	53	16	6	20 ^{+0,4}	15,5	
RG3R -15-2 MCRF													15,5		
RG4L -15-2 MCRF													20 ^{+0,4}		
RG4R -15-2 MCRF													15,5		
RG3L -20-2 MCRF	1,33	124	84	20	70	40	M6	37	37,5	68	17,5	9,5	32 ^{±0,4}	21	
RG3R -20-2 MCRF													21		
RG4L -20-2 MCRF													32 ^{±0,4}		
RG4R -20-2 MCRF													21		
RG3L -22-2 MCRF	1,33	124	84	22	70	40	M6	37	37,5	68	17,5	9,5	32 ^{±0,4}	21	
RG3R -22-2 MCRF													21		
RG4L -22-2 MCRF													32 ^{±0,4}		
RG4R -22-2 MCRF													21		

RG Types

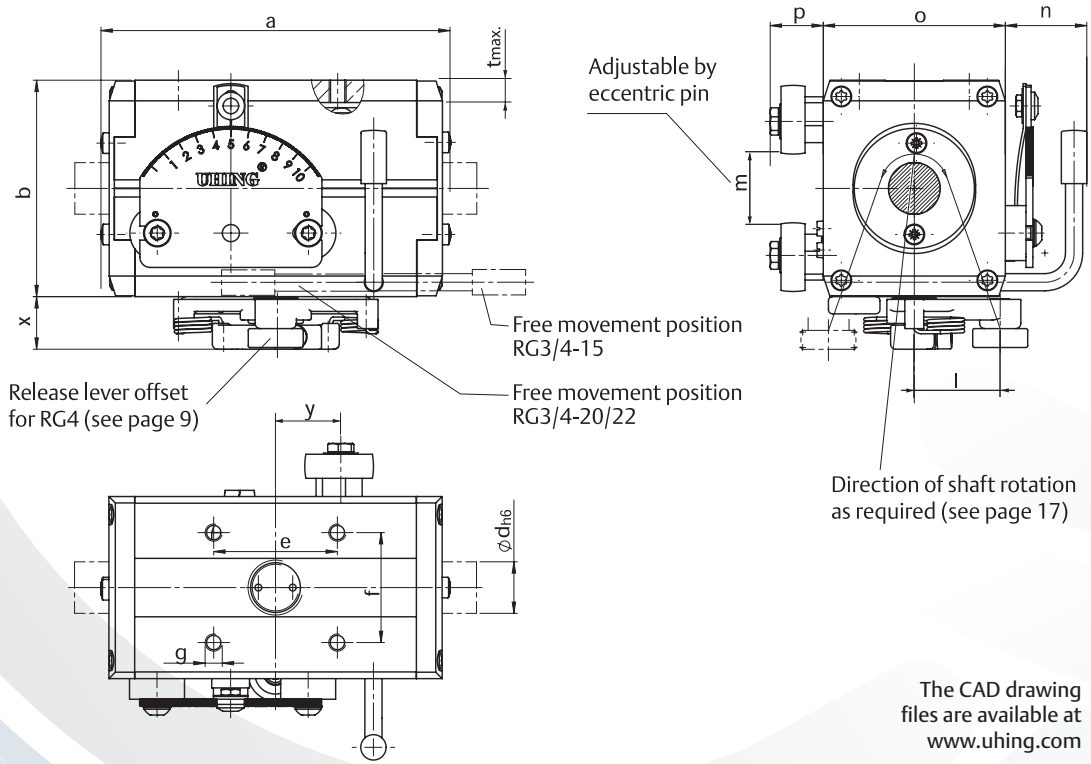

The CAD drawing files are available at www.uhing.com

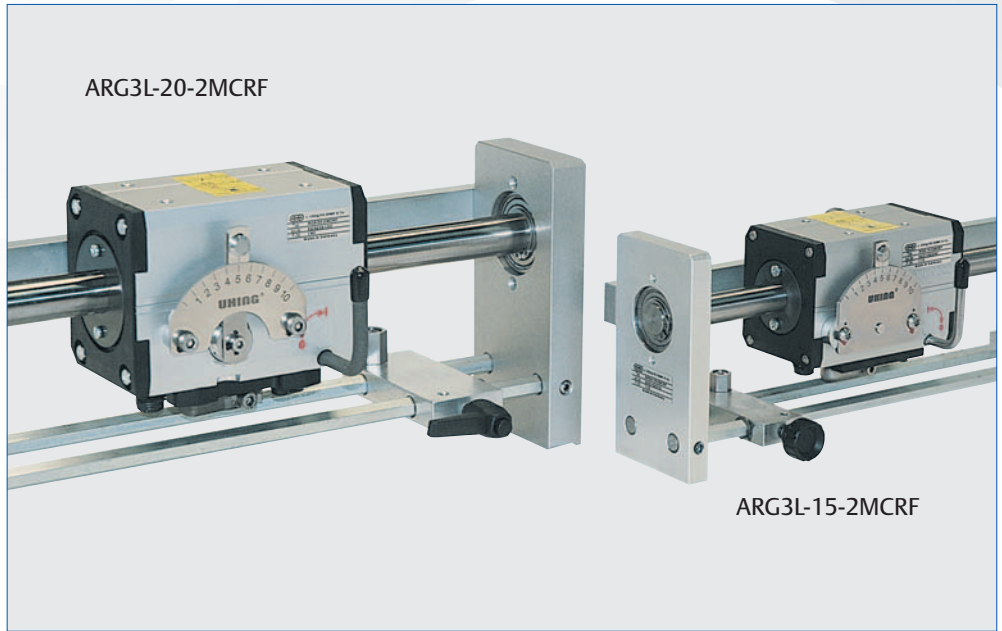

Dimensions and technical details

Uhing Rolling Ring Drive Types RG and ARG

Additional dimensions for ARG Types (mm)

Technical details (see page 20)

	r	u	i	k	l ₁ *	p	s	t	v	w	z	**Bracket L ≥	F _{RG} (N)	M ₀ (Ncm)	h _{max} (mm)
ARG3L-15-2MCRF ARG3R-15-2MCRF	75	112	20	M6	150	60	106	30	3	12	53	750	110	2,5	11,1
ARG4L-15-2MCRF ARG4R-15-2MCRF	75	112	20	M6	180	60	106	30	3	12	53	750	220	4,8	11,1
ARG3L-20-2MCRF ARG3R-20-2MCRF	104	145	24	M12	200	70	143	36	5,5	20	63	850	160	2,5	15,5
ARG4L-20-2MCRF ARG4R-20-2MCRF	104	145	24	M12	210	70	143	36	5,5	20	63	850	320	5,1	15,5
ARG3L-22-2MCRF ARG3R-22-2MCRF	104	145	24	M12	200	70	143	36	5,5	20	63	850	160	3,0	16,5
ARG4L-22-2MCRF ARG4R-22-2MCRF	104	145	24	M12	210	70	143	36	5,5	20	63	850	320	5,1	16,5

ARG Types

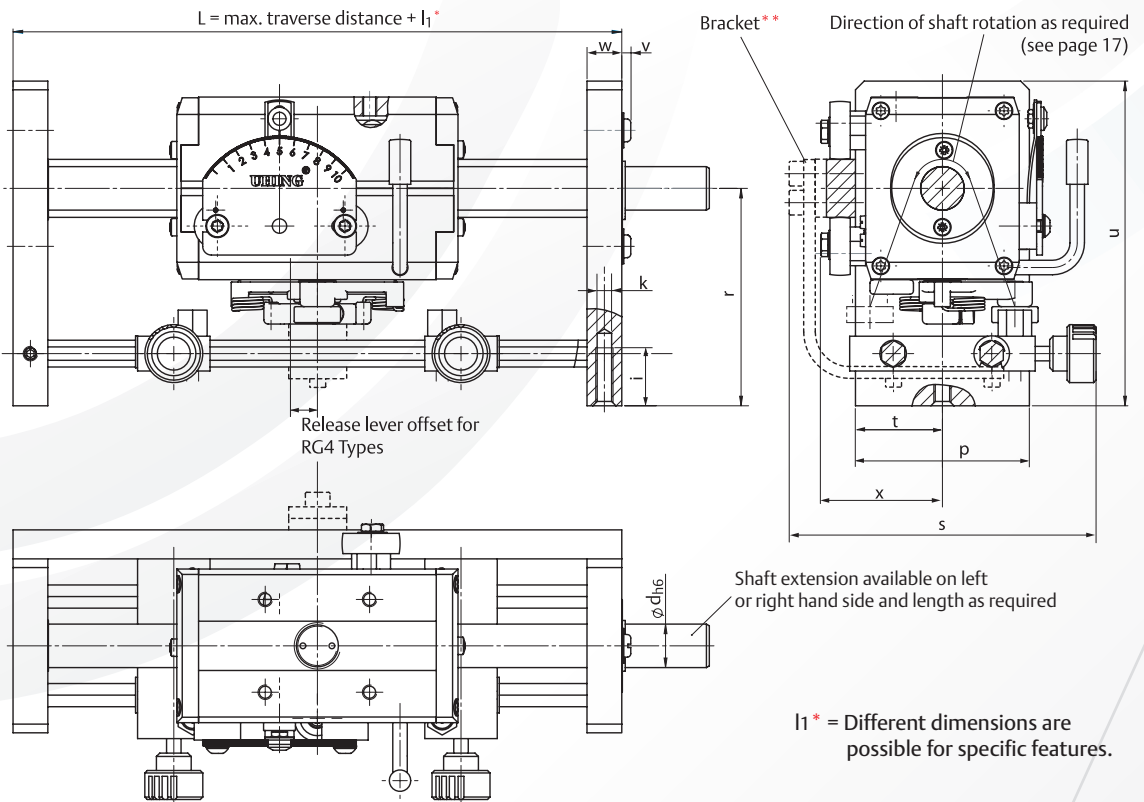

Dimensions and technical details

Uhing Rolling Ring Drive Types RG and ARG



Types	Dimensions for RG Types (mm)													
	Weight (kg)	a	b	Ødh6	e	f	g	l	n	o	p	t _{max.}	m	x
RG3L-30-2MCRF RG3R-30-2MCRF	2,7	150	105	30	80	50	M6	52	42,5	86	18,5	12	40±0,6	24,5
RG4L-30-2MCRF RG4R-30-2MCRF	3,2	180	105	30	80	50	M6	52	42,5	86	18,5	12	40±0,6	24,5
RG3L-40-2MCRF RG3R-40-2MCRF	4,4	182	128	40	100	68	M10	70	68	110	20	12	50±0,5	25,5
RG4L-40-2MCRF RG4R-40-2MCRF	5,3	210	128	40	100	68	M10	70	68	110	20	12	50±0,5	25,5

RG Types

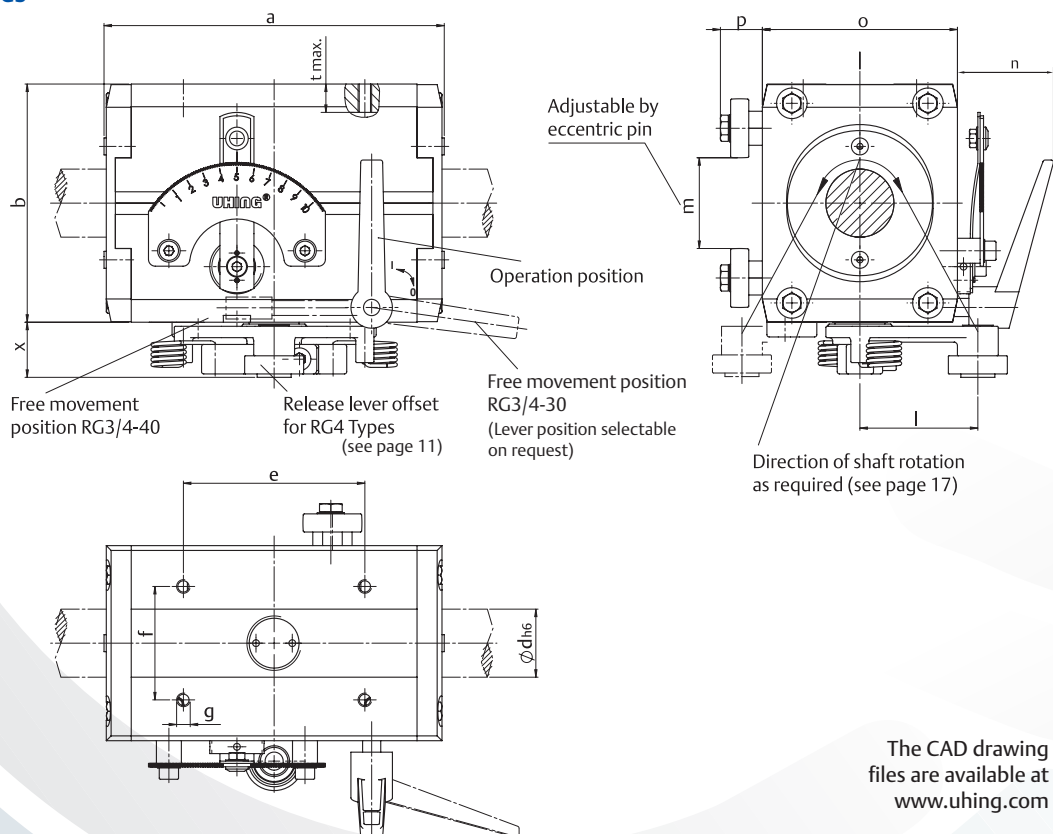

The CAD drawing files are available at www.uhing.com

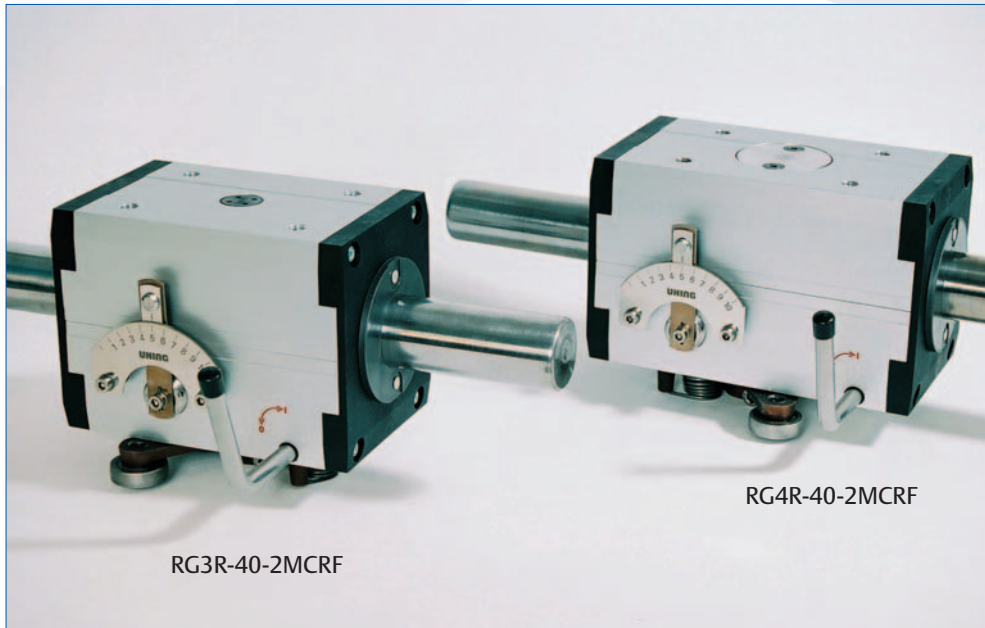

Dimensions and technical details

Uhing Rolling Ring Drive Types RG and ARG

Additional dimensions for ARG Types (mm)

	t	z	i	k	l ₁ *	p	s	u	v	w	** Bracket L ≥	Technical details (see page 20)		
												F _{RG} (N)	M ₀ (Ncm)	h _{max} (mm)
ARG3L-30-2MCRF ARG3R-30-2MCRF	120	175	25	M12	240	89	182,5	45	7	20	940	260/400	8/10,2	24
ARG4L-30-2MCRF ARG4R-30-2MCRF	120	175	25	M12	280	89	182,5	45	7	20	940	520	12	24
ARG3L-40-2MCRF ARG3R-40-2MCRF	150	220	32	M16	320	114	230,5	57	6,5	30	1100	420	28	32
ARG4L-40-2MCRF ARG4R-40-2MCRF	150	220	32	M16	350	114	230,5	57	6,5	30	1100	840	50	32

ARG Types

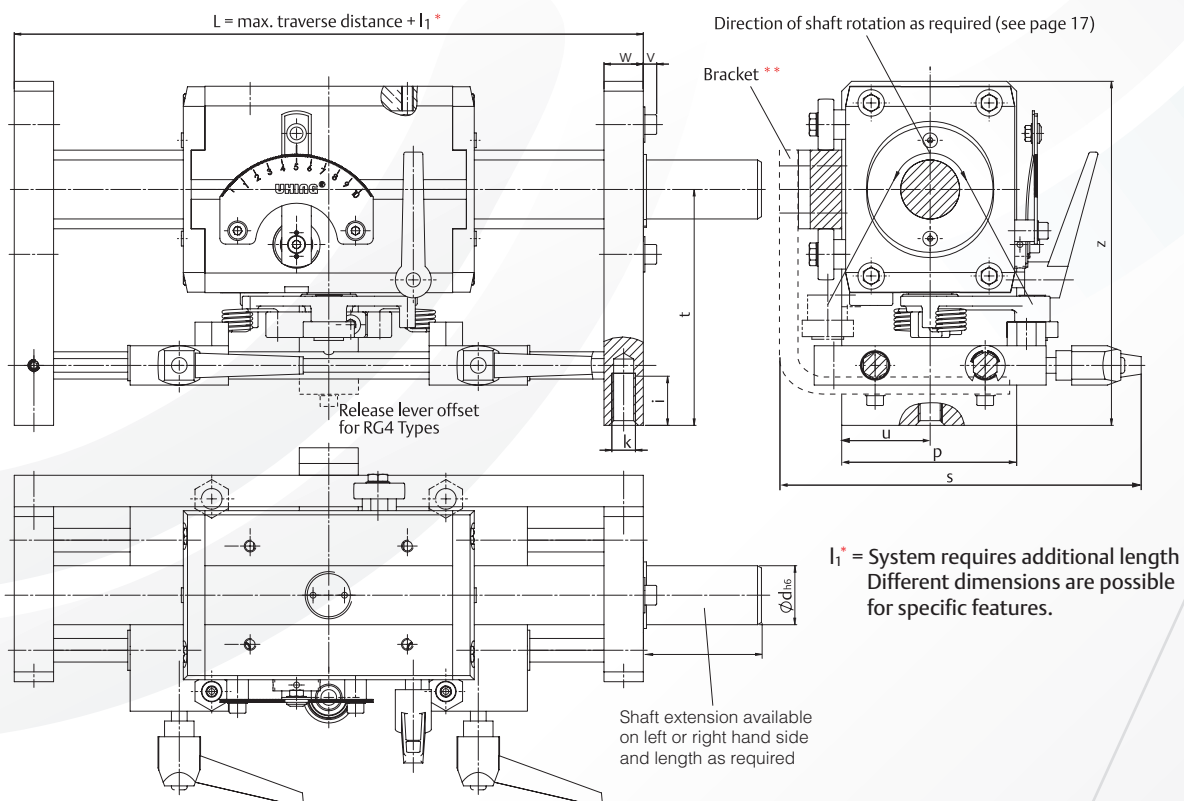

Dimensions and technical details

Uhing Rolling Ring Drive Types RG and ARG

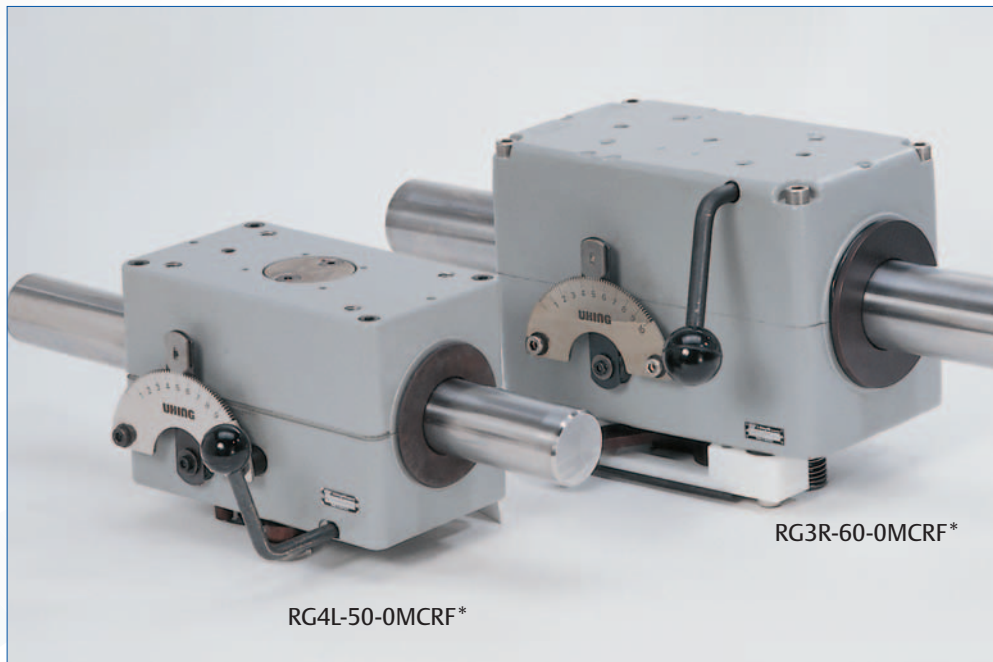

Dimensions for RG Types (mm)

Types	Weight (kg)	a	b	Ød _{h6}	e	f	g	l	n	o	p	t _{max}	c	x
RG3L-50-0MCR RG3R-50-0MCR	9,8	240	154	50	160	90	M12	70	22,5	132	35	15	65	25,5
RG4L-50-0MCR RG4R-50-0MCR	11,1	240	154	50	160	90	M12	70	22,5	132	35	15	65	25,5
RG3L-60-0MCR RG3R-60-0MCR	17,0	297	190	60	120	80	M12	114	25,5	160	34	15	100	40
RG4L-60-0MCR RG4R-60-0MCR	19,6	297	190	60	120	80	M12	114	25,5	160	34	15	100	40
RG3L-80-0MCR RG3R-80-0MCR	27,0	368	236	80	240	80	M12	114	22,5	188	42	19	92	40
RG4L-80-0MCR RG4R-80-0MCR	32,0	368	236	80	240	80	M12	114	22,5	188	42	19	92	40

RG Types

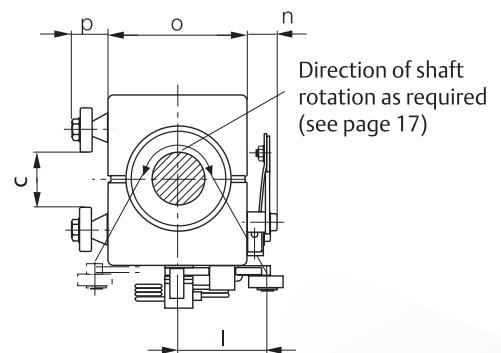
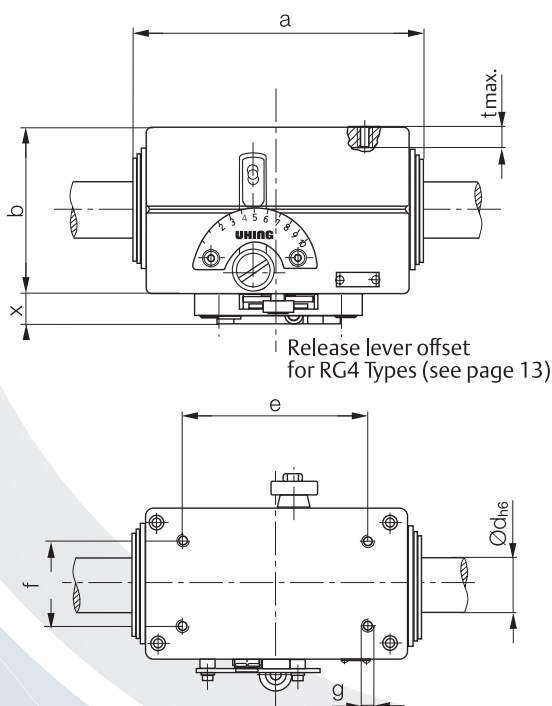

The CAD drawing files are available at www.uhing.com

Dimensions and technical details

Uhing Rolling Ring Drive Types RG and ARG

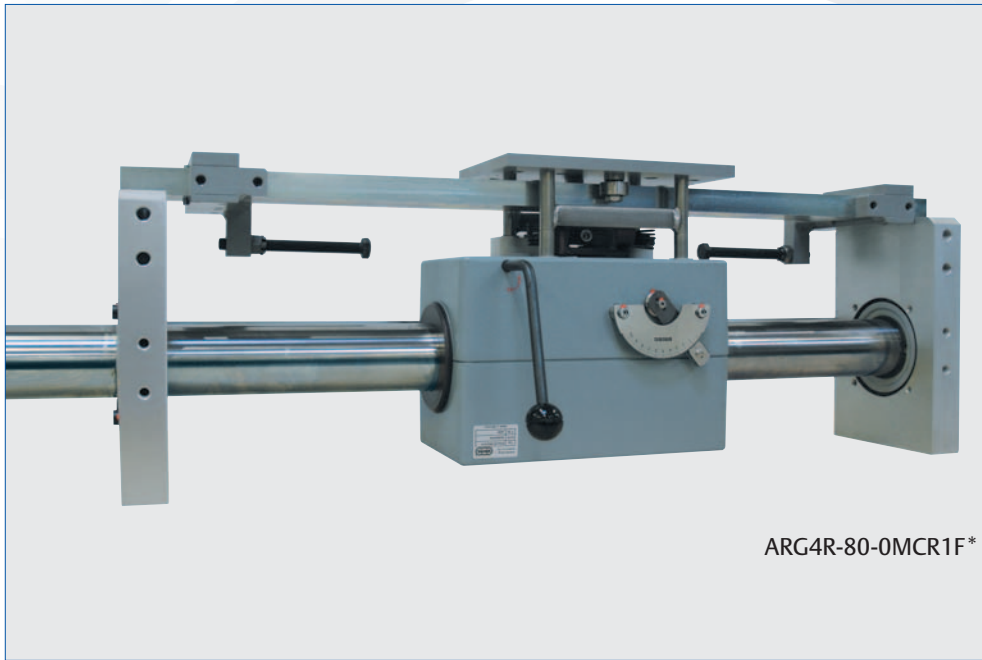

ARG4R-80-0MCR1F*

Additional dimensions for ARG Types (mm)

	e ₁	e	f	g	r	m	i	k	l ₁ *	p	s	t	u	v	w	z	y	Heavy duty steady bar L ≥	Technical details (see page 20)		
																			F _{RG} (N)	M ₀ (Ncm)	h _{max} (mm)
ARG3L-50-0MCR ARG3R-50-0MCR	160	0	90	M12	91	235 250 ¹⁾	32	M16	460	150	176 181 ¹⁾	12	256 271 ¹⁾	9,5	38	190	130	2000	700	70	40
ARG4L-50-0MCR ARG4R-50-0MCR	160	0	90	M12	91	235 250 ¹⁾	32	M16	460	150	176 181 ¹⁾	12	256 271 ¹⁾	9,5	38	190	130	2000	1400	120	40
ARG3L-60-0MCR ARG3R-60-0MCR	240	120	80	M12	140	330 340 ²⁾	35	M16	580	170	253	15	352 362 ²⁾	8	48	300	180	3000	1000	90	48
ARG4L-60-0MCR ARG4R-60-0MCR	240	120	80	M12	140	330 340 ²⁾	35	M16	580	170	253	15	352 362 ²⁾	8	48	300	180	3000	2000	150	48
ARG3L-80-0MCR ARG3R-80-0MCR	240	120	80	M12	140	350 380 ³⁾	35	M16	620	200	268	15	375 405 ³⁾	8	48	300	180	3600	1800	300	70
ARG4L-80-0MCR ARG4R-80-0MCR	240	120	80	M12	140	350 380 ³⁾	35	M16	620	200	268	15	375 405 ³⁾	8	48	300	180	3600	3600	350	70

1) with L ≥ 2000, 2) with L ≥ 3000, 3) with L ≥ 3600

ARG Types

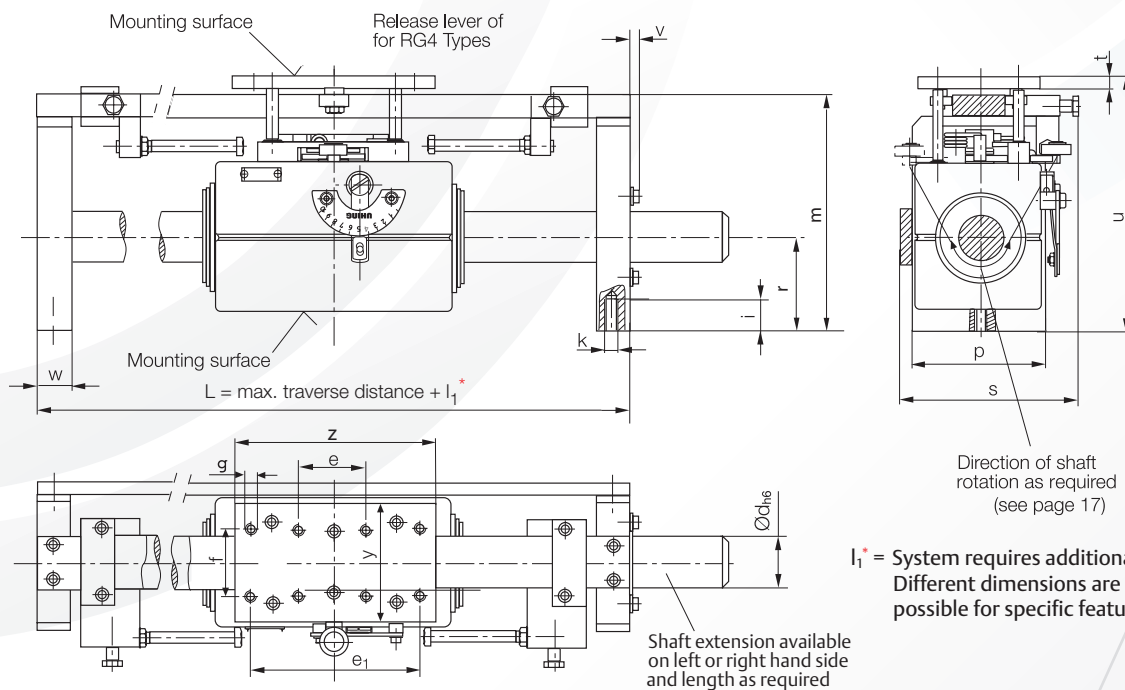

Dimensions and technical details

Uhing Rolling Ring Drive Types RGK and ARGK

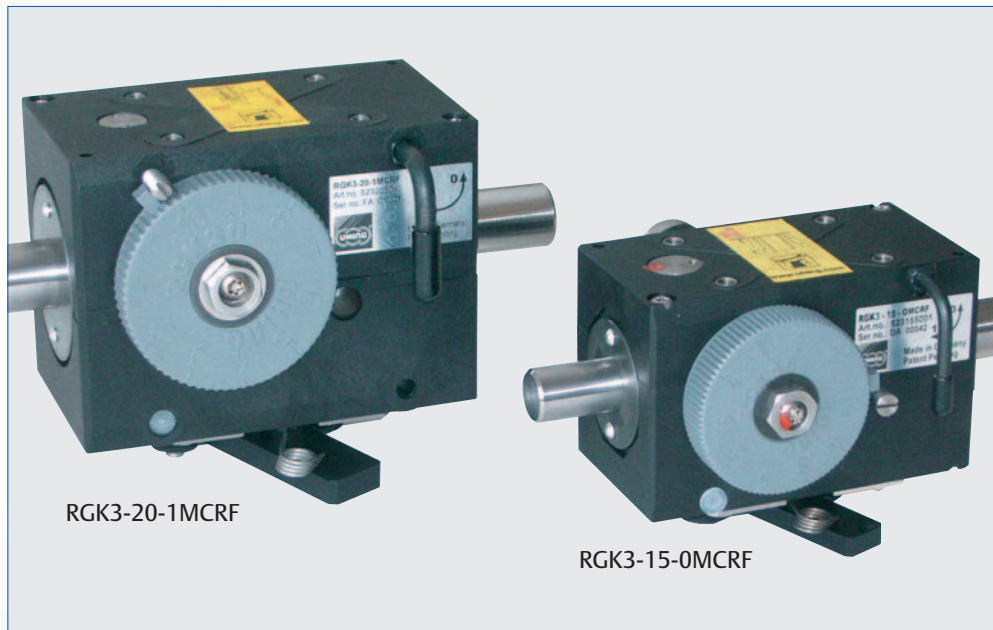

RGK3-20-1MCRF

RGK3-15-0MCRF

Dimensions for RG Types (mm)

Types	Weight (kg)	Dimensions (mm)																		
		a	b	c	d	Ødh6	e	f	g	h	i	k	l	m	n	o	p	tmax	q	Ør
RGK3-15-0	0.53	100	63	19,1	34	15	15	30	20±0.4	17.0	53	32.8	15.8	39.5	6	70	46	9	M5	4
RGK3-20-1	0.90	120	86	23	42	20	18	36	32±0.4	17.5	68	40.5	20	53.5	8	90	54	11	M5	6
RGK3-22-1	0.90	120	86	23	42	22	18	36	32±0.4	17.5	68	40.5	20	53.5	8	90	54	11	M5	6

RGK Types

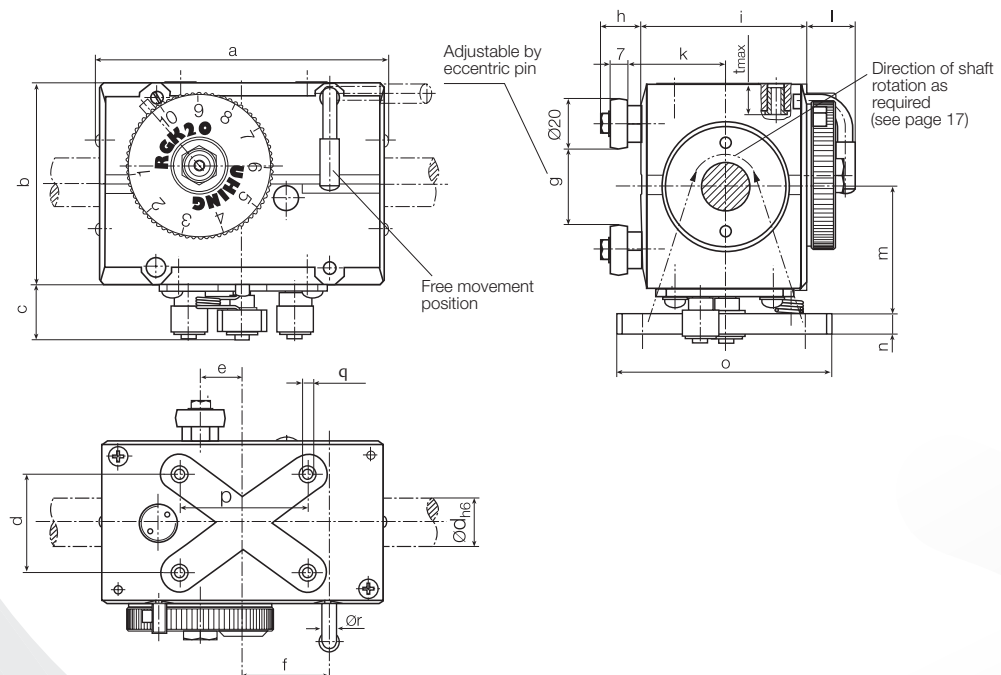

The CAD drawing files are available at www.uhing.com

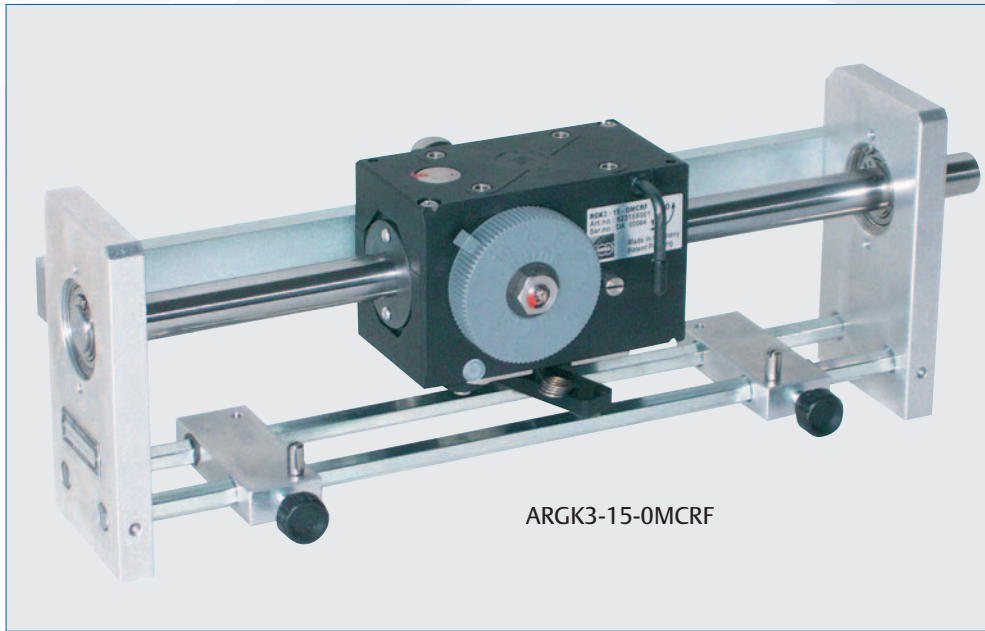

ARGK3-15-0MCRF

Dimensions and technical details

Uhing Rolling Ring Drive Types RGK and ARGK

Additional dimensions for ARGK Types (mm)

Technical details (see page 20)

	f	h ₁	h ₂	i	k	l ₁	m	n	p	s	t	v	w	x	*Bracket L ≥	F _{RG} (N)	M _O (Ncm)	h _{max} (mm)
ARGK3-15-0	57	75	112	20	M6	150	6	30	60	53	30	3	12	53	750	90	2.0	8
ARGK3-20-1	72	104	147	24	M12	200	10	40	70	79	36	5.5	20	63	850	130	3.0	12
ARGK3-22-1	72	104	147	24	M12	200	10	40	70	79	36	5.5	20	63	850	130	3.0	13

ARGK Types

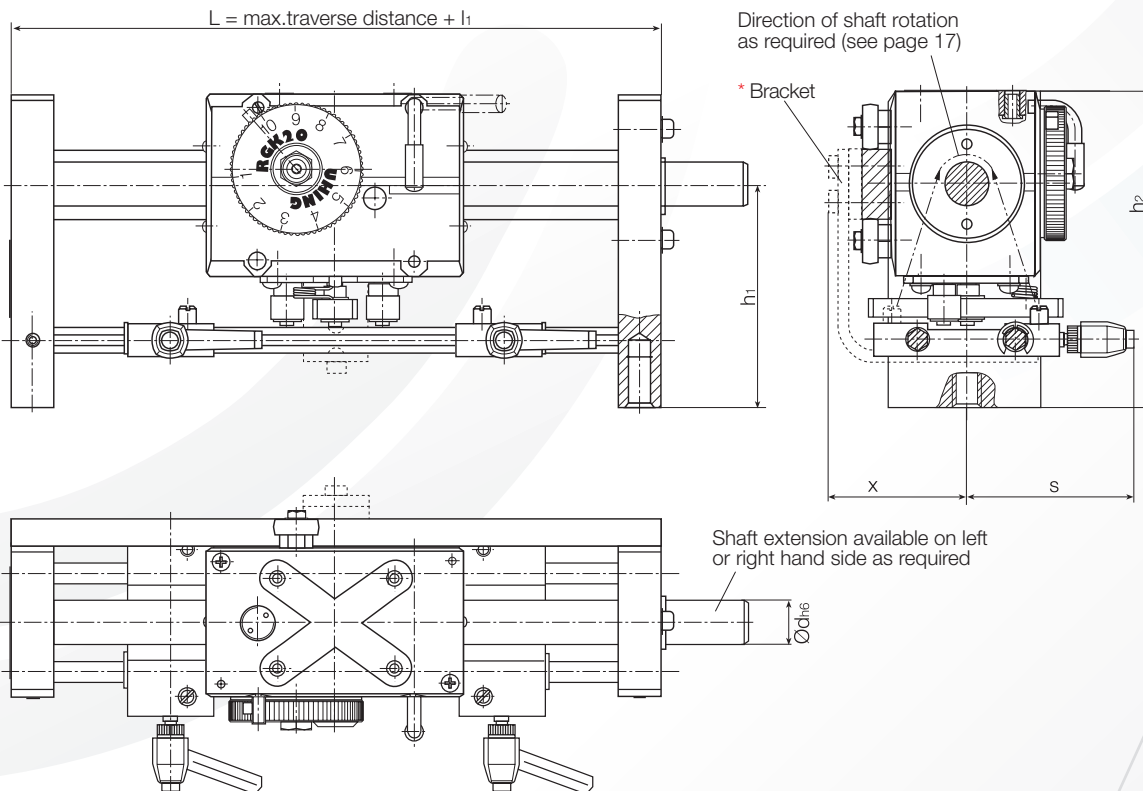

Dimensions and technical details

Uhing Rolling Ring Drive Types KI and AKI



KI3L-15-6 MCR

Dimensions	Weight (kg)	Max. side thrust FRG (N)	Drive torque M_0 (Ncm)	Max. pitch h (mm)
Type				
KI3R-15-6 MCR KI3L-15-6 MCR	0.28	30	6±0.5	6.0

Type KI3-15-6MCR

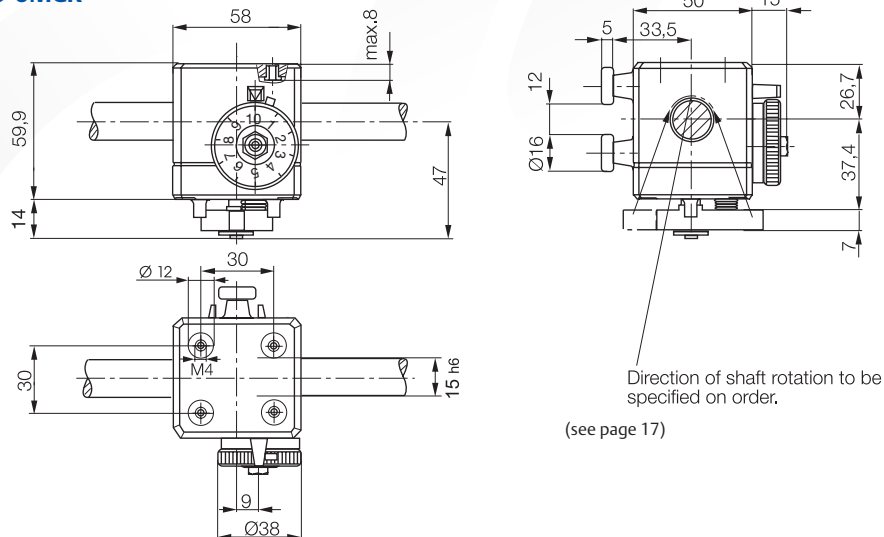

Type AKI3-15-6MCRW

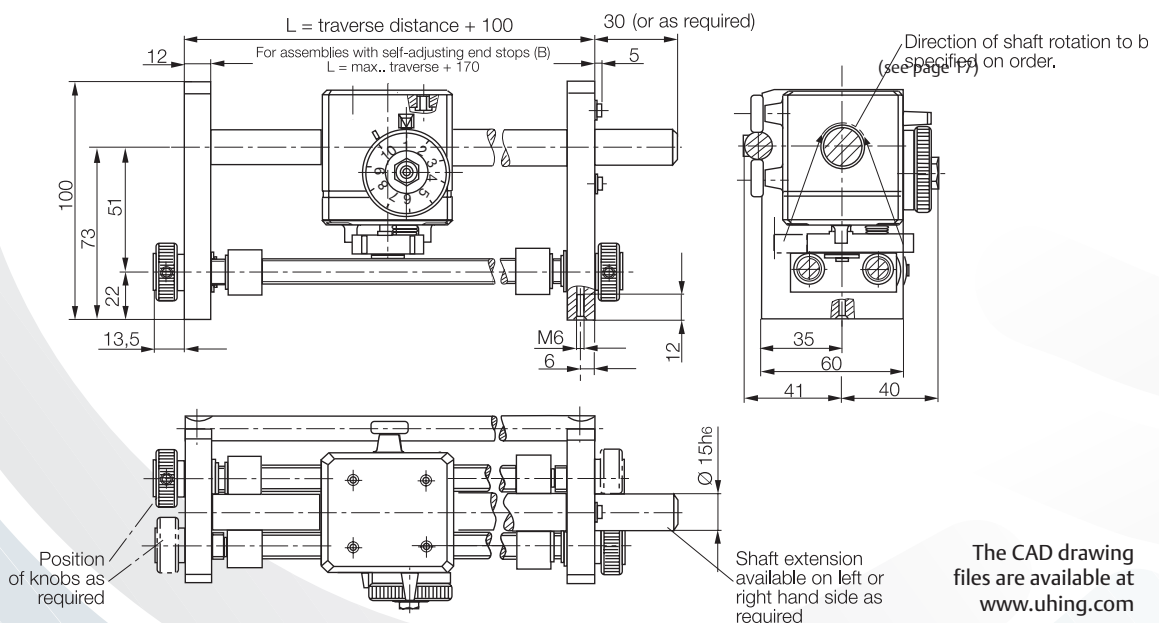

The CAD drawing files are available at www.uhing.com

Product Survey and Ordering Information

Product Survey

Uhing Linear Drives®												
Product Group	Rolling Ring Drive											Kinemax
Type Reference	RG page 8/10/12 ARG page 9/11/13								RGK p.14 ARGK p.15			KI page 16 AKI page 16
Style Number of rolling rings	3 or 4								3			3
Size Shaft diameter	15	20	22	30	40	50	60	80	15	20	22	15
Design Category	2	2	2	2	2	0	0	0	0	1	1	6
Direction of shaft rotation L = left R = right	L, R								RGK independent ARGK L, R			L, R
Features	see page 18 - 19								s. page 18-19			
Customer Specific Features	see page 19								wipers			see page 19
Max. Pitch (mm)	11.1	15.5	16.5	24	32	40	48	70	8.0	12.0	13.0	6.0

Example of Ordering Specification

Types	KI, AKI, RGK, ARGK, RG, ARG														
↑	↑	↑	↑	↑	↑	↑	↑	↑	↑	↑	↑	↑	↑	↑	↑
Drive system support frame	Rolling ring drive	Number of rolling rings	Shaft-rotation	Shaft diameter Ø (mm)	Development status	Switching	Pitch adjustment	Roller guide	Free movement lever	Stroke adjustment	Standstill and start-up trigger	Load carriages	Client specific feature		
A	KI RG	3 4	L R <small>not necessary if shaft rotation is independent</small>	15 80	0 9	D E H K M N V	C S Z	R R1	F P	B W	0 01 02	LZ	X *		

* X e.g. Adapter (twist-free coupling), intermediate support bracket, heavy duty steady bar, drive motor, wipers, special paint finish, additional anti-corrosion protection, double bearing support, special pitch, noise dampening, sequence control, etc.

The following is required additionally:

Direction of shaft rotation
to the right = R
to the left = L

Shaft extension, diameter and length (mm)
ra = extending beyond the righthand bracket when looking at the pitch selection scale
la = extending beyond the lefthand bracket when looking at the pitch selection scale

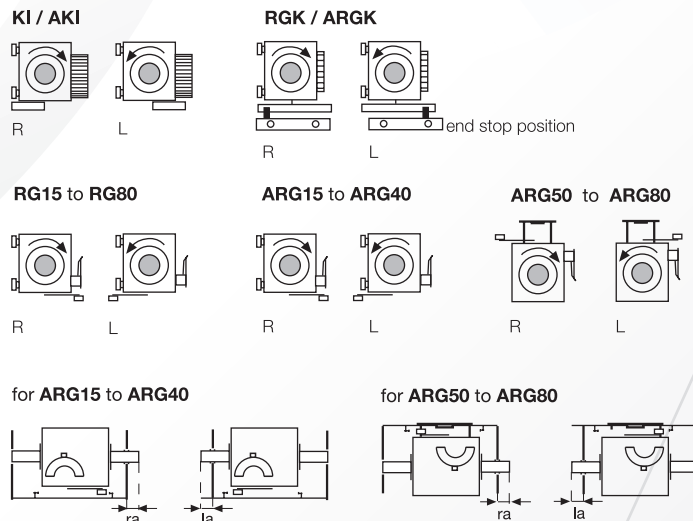

Features

Standard

Rolling Ring Drives Types KI, RGK and RG
 KI 3-15, RGK3-15/20
 RG 3/4-15 to RG 3/4-80

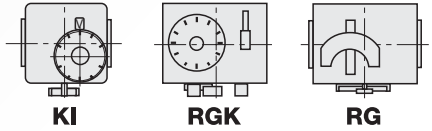

Rolling Ring Drives Types AKI, ARGK and ARG
 Rolling Ring Drive Units KI, RGK and RG with shaft, steady bars, end brackets and end stops

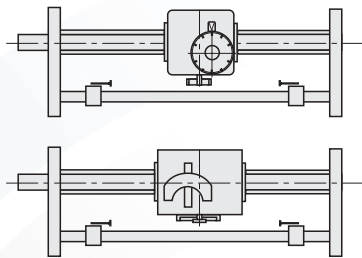

Additional

Attention: The dimensions and technical Details on the pages 8 to 16 are only valid for the features MCRF resp. MCR/MCR1. For different features ask for dimensional drawings.

Reversal

D Two-way shaft rotation

Reversal mechanism suitable for either direction of shaft rotation. Push-rod not supplied.

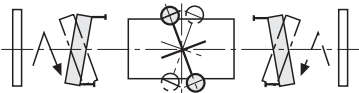

H Control lever, double-sided

Provides reversal slowdown over short and adjustable slowdown length. Can be used to provide slowdown control both before and after the reversal.

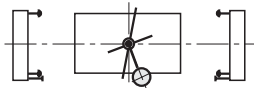

M Instantaneous reversal

Mechanical spring operated trigger action automatic reversal of the direction of travel. Minimum length of stroke = approx. 1x shaft diameter.

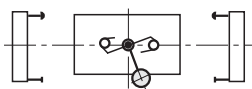

N *1 Pneumatic

The direction of travel is reversed by the action of a two-way pneumatic cylinder (operating pressure = 6 bar).

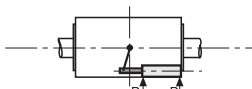

V Reversal slowdown

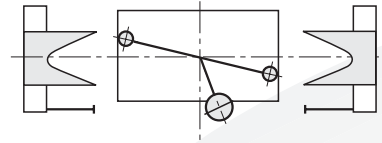

Reversal slowdown for slowdown lengths in excess of 15 mm via cam and contact lever system.

Pitch setting

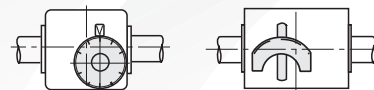

C Scale

Pitch setting via knob (KI/ RGK) or the engagement of a lever in a serrated scale (RG). Simultaneous setting of the same pitch in both directions of travel.

S Set screws

Infinitely variable pitch setting - separate settings for each direction.

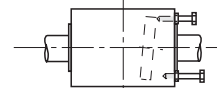

Z Worm drive

Simultaneous infinitely variable setting of the same pitch in each direction of travel. Types RG: Supplied without wormwheel drive shaft. If required, an operation knob is available (X.)

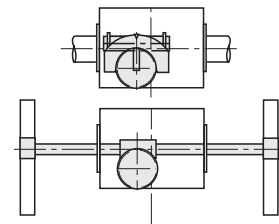

Types ARG: Supplied with worm drive shaft for remote adjustment from either end (to be specified).

Also available with adjustment control (X).

Steady rollers

R

Rollers on rear of unit which (in conjunction with a rear steady bar) prevent the rotation of the unit on the shaft.

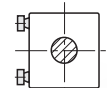

Standard with RG3/4-15 to RG3/4-80, ARG3-15 to ARG3/4-40 and RGK3-15/20/22 and ARGK3-15/20/22

R1

Rollers fitted to separate top mounting plate assembly, used in conjunction with a top steady bar to prevent the rotation of the unit on the shaft. ARG 3/4-50 to ARG3/4-80.

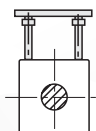

Free-Movement lever

F Mechanical

After operation of the free-movement lever, the unit can be pushed freely along the shaft.

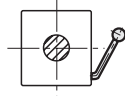

Standard with RG3/4-15 to RG3/4-40 and RGK

P Pneumatic

Side thrust of the unit is achieved pneumatically, free movement (pushing the unit freely along the shaft) by venting the diaphragm cylinder. System also suitable for remote control.

Operating pressure = 6 bar

Please note: In vertical applications, before operating the free-movement lever please ensure that the load cannot fall in an uncontrolled manner. Injury can result!

Attention: All Rolling Ring Drive Units, especially if fitted with feature F or P are not allowed to be rigidly connected to a separate load carrier.

Stroke width adjustment

B Self-adjusting end stops

For continuously increasing or decreasing the traverse width

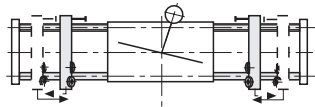

during the winding operation. Only recommended with units having a free-movement lever (F). Please consult supplier if application is vertical.

W Lead screw operated end stops

Remote lead screw adjustment of the traverse width operated from

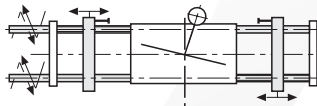

one of the end bracket positions. Can also be supplied with a handwheel control or with a control motor drive (X).

Stopping on a rotating shaft and restarting

O Stopping

The Rolling Ring Drive is brought to a standstill position on the rotating shaft by reducing the pitch to 0. Only available in combination with units having reversal type H, K and V. Restart via O1 or O2.

(For information concerning standstill times, please consult supplier)

O1 Pneumatic restart

Restart activated by a single action pneumatic cylinder (operating pressure = 6 bar) which operates the reversal mechanism.

O2 Electro-magnetic restart

Restart activated by solenoids (operating voltage 24 V D.C.) which operate the reversal mechanism.

Load carrier

LZ

Roller style load carrier designed to absorb loads and twisting forces (dimensions upon request).

Customer specific special features

X

Adapter (twist-free coupling)

Angle bracket

Heavy duty steady bar

Drive motor

Wipers

Special paint finish

Anti-corrosion protection

Double bearing support

Special pitch

Noise dampening

Sequence control

etc.

*1

Reversal characteristic **N** can be further combined with reversal characteristics **H** and **V** and with stopping character (**O**). With such combination, an additional restart system (**O1**) or (**O2**) is not required as the restart can be activated by pneumatic cylinder (**N**).

We reserve the right to make technical alterations.

Technical basics

Selection

1. Formulae and related units

$a(\text{m/sec}^2)$	= acceleration at the reversal point
$d(\text{mm})$	= shaft diameter
$F(\text{N})$	= side thrust required
$F_{RG}(\text{N})$	= side thrust produced by Rolling Ring Drive Unit
$F_R(\text{N})$	= friction ($F_N \cdot \mu$) only relevant when the the associated mass is mounted on its own independent carriage
$F_N(\text{N})$	= normal force of total weight of associated mass and carriage
μ	= coefficient of friction
$F_z(\text{N})$	= additional force e.g. component of the cutting force of a separator
$f(\text{mm})$	= shaft sag from Fig.1
$g(\text{m/sec}^2)$	= acceleration due to gravity (9.81m/sec^2)
$h(\text{mm})$	= pitch of unit (travel per shaft revolution)
$h_{\text{max}}(\text{mm})$	= maximum pitch see Fig.3
$l(\text{mm})$	= length of shaft between centres of bearing brackets
$m(\text{kg})$	= total mass to be moved, including the Rolling Ring Drive Unit, connections etc.
$M_d(\text{Ncm})$	= drive torque
$M_o(\text{Ncm})$	= idling torque
$n(\text{r.p.m.})$	= shaft speed
$n_{\text{crit}}(\text{r.p.m.})$	= critical shaft speed
$P(\text{kW})$	= drive power required
$s(\text{mm})$	= length of reversal slowdown cam
$t(\text{sec})$	= reversal time from Fig.2
$v(\text{m/sec})$	= max. traverse speed required. Should always be calculated at maximum unit pitch (pitch setting 10 from Fig.2)
$C(\text{N})$	= dynamic loading of Rolling Rings
$P_r(\text{N})$	= radial loading of Rolling Rings

2. Preselection

A unit should be preselected by estimating the side thrust required and/or giving consideration to the permissible shaft sag f with reference to Fig. 1.

Fig. 1

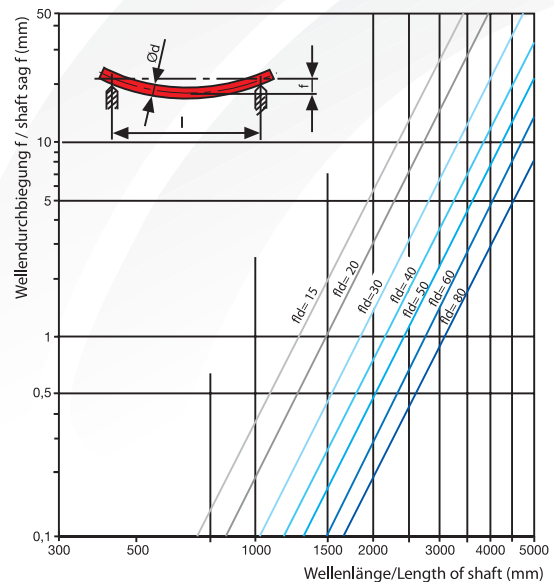

2.1. Rolling Ring Drive Units with Instantaneous Reversal (Feature M)

Suitable for traversing speeds up to:
 Kinemax, RG15, RG20: 0.30 m/sec
 RG30, RG40: 0.40 m/sec
 RG50, RG60, RG80: 0.25 m/sec

Calculation of side thrust required:

$$F = 2.5 \frac{m \cdot v}{t} + F_R + F_z + 1.25 \cdot m \cdot g + (F_k)^*$$

*see section 6 - Winding Applications

The reversal time t is dependent on the size of the Rolling Ring Unit and the pitch selected via the scale (pitch angle). The reversal action is of the triggered throwover type.

To find reversal time t :

Using the pitch selection scale value 10 in Fig. 2, find the curve for the appropriate unit size and read off the corresponding reversal time t .

Note:

The value of side thrust F calculated must be less than that of the Rolling Ring Drive Unit selected.

$$F < F_{RG}$$

If necessary, select a different size of unit and repeat the process. For winding applications please also refer to section 6.

Reduce shaft sag by doubled shaft bearing.

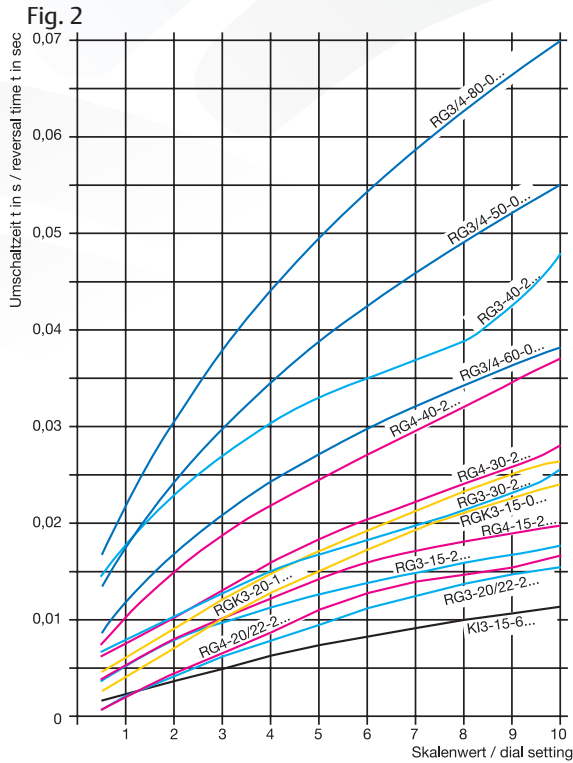

2.2 Rolling Ring Drive Units with reversal slowdown (Feature V)

Suitable for traverse speeds up to approx. 4.2 m/sec. A reversal with slowdown reduces the forces imposed on the unit at the reversal point.

$$F = 1.25 \cdot m \cdot a + F_R + F_Z + 1.25 \cdot m \cdot g$$

If a maximum rate of acceleration a is specified, the required length s for the delay cam is calculated as follows:

$$s = \frac{v^2 \cdot 10^3}{a}$$

If the delay cam length s is specified, the acceleration a is calculated as follows:

$$a = \frac{v^2 \cdot 10^3}{s}$$

3. Side thrust

The value of side thrust F calculated must be less than that of the Rolling Ring Drive Unit selected.

$$F < F_{RG}$$

If the side thrust available from the unit chosen is too little, either a larger unit or a longer length of delay must be selected.

The thrust provided by the units is virtually constant for shaft speeds above 300 rpm. For slower speeds the thrust increases a little over the specified catalogue values as the speed reduces towards zero.

For increase of lifetime there should only be adjusted the side thrust which is needed as a result of calculation according to 2.1 and 2.2.

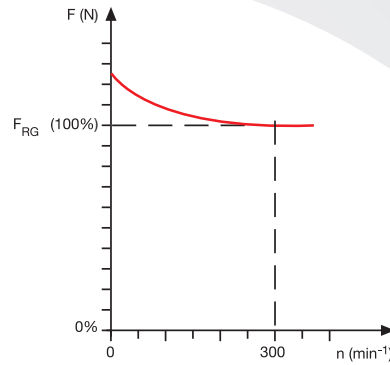

Measuring of sidethrust in the middle of the Rolling Ring Drive.

Change in side thrust related to shaft speed

4. Shaft Speed

4.1. Calculation

$$n = \frac{v \cdot 6 \cdot 10^4}{h_{\max}}$$

The speed so calculated must not be exceeded.

Recommended speed range:

$$n_{\min} = 5 \text{ rpm}$$

$$n_{\max} = 3000 \text{ rpm}$$

For speeds outside this range, please consult supplier.

The pitch h is obtained by taking the 10 setting value for the pitch selection scale and relating it to the graph for the appropriate unit size. (Fig. 3)

Minimum traverse stroke:

Feature M (see Page 11) $\approx 1 \times d$

Feature E+N > 0

Fig. 3

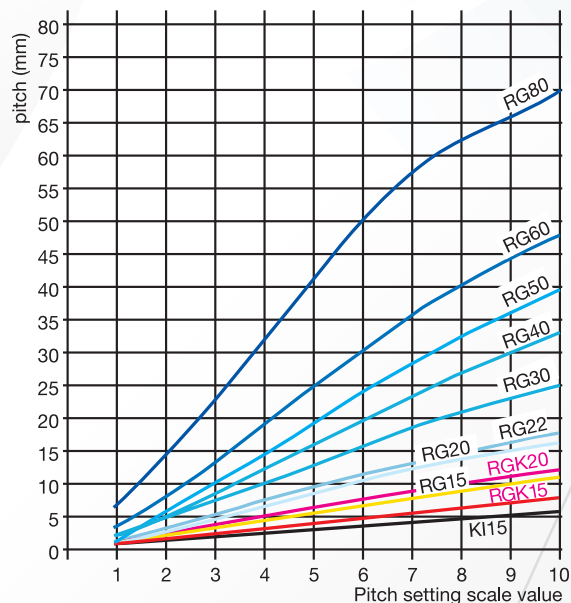

4.2. Critical shaft speed

$$n_{crit} = 1.225 \cdot 10^8 \frac{d}{l^2}$$

Note:

Depending upon its quality, the shaft can go out of balance at a speed of up to 25% lower than that specified above.

If it is necessary to go through a critical range in order to reach the operational speed, this can lead to short term shaft vibration. This has no effect on the operation of the drive.

If the operational speed is in the critical speed range, this can be rectified as follows:

1. with a double bearing support at one end:
Increase factor approx. 1.5.
2. with double bearing supports at both ends:
Increase factor approx. 2.2.

The distance between the bearing support brackets should be at least 2.5 x the diameter of the shaft.

5. Shaft Drive

5.1. Drive Torque

$$M_d = \frac{F_{RG} \cdot h_{max}}{20 \cdot \pi} + M_o$$

Value for M_o to be taken from the technical data section.

5.2. Drive Power Requirement

$$P = \frac{M_d \cdot n}{9550 \cdot 10^2}$$

6. Winding applications

6.1. Formulae and related units

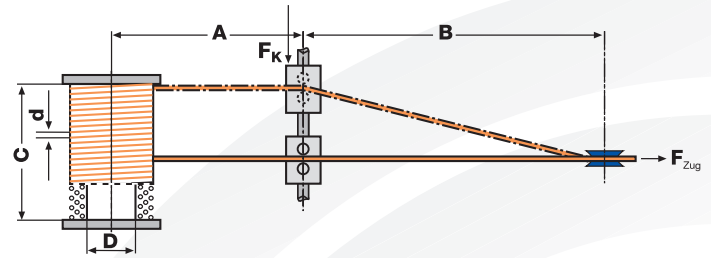

- A(mm) = distance between traverse and spool
- B(mm) = distance between previous pay-off
- C(mm) = traverse width
- D(mm) = barrel diameter of bobbin
- d_{max} (mm) = maximum diameter of material to be wound or maximum pitch
- F_{Zug} (N) = tension in the material to be wound
- F_k (N) = component of force working against the direction of travel of the traverse
- h_{max} (mm) = max. pitch of unit selected, taken from the technical data section
- v_w (m/sec) = winding line speed

6.2. Tension

In winding operations, the force F_k acting on the traverse and related to the tension F_{Zug} in the material to be wound is a major factor in the selection of a Rolling Ring Traverse.

As, almost invariably, traverses with instantaneous

$$F_k = \frac{C \cdot F_{Zug}}{1,6 \cdot \sqrt{\frac{C^2}{4} + B^2}}$$

reversal are used for winding applications, the value calculated for F_k must be added to the side thrust required figure taken from section 2.1.

6.3. Calculation of traverse speed

$$v = \frac{v_w \cdot d_{max}}{D \cdot \pi \cdot 0.95}$$

6.4. Optimum ratio between spool shaft and traverse shaft speeds

$$i_{opt} = \frac{0.95 \cdot h_{max}}{d_{max}}$$

- $i_{opt} > 1$ = RG traverse shaft slower
- $i_{opt} < 1$ = RG traverse shaft faster

6.5. Please note

Pitch settings lower than "1" on the scale should be avoided if the requirement is for a high quality of wind. Compensate by changing the ratio between the spool shaft and traverse shaft speeds (reduce traverse shaft speed).

7. Calculation of the operational life of Uhing Rolling Rings

1. C Determine a value for:

Type RG	C ₁ (N)	C ₂ (N)
15/KI/RGK	6050	2800
20/22/RGK	11200	5600
30	16800	9300
40	21600	13200
50	29600	18300
60	37700	24500
80	58800	39000

C₁ = Unit operating continuously on rotating shaft without a standstill

C₂ = Unit operating continuously and including a standstill on a rotating shaft

2. Calculate P_R

KI, RGK and all RG3-types: $P_R = 5 \cdot F_{RG}^*$
all RG 4-types: $P_R = 2.5 \cdot F_{RG}^*$

*F = calculated value of the side thrust according to 2.1 and 2.2 only if increasing of operational life time of the Rolling Rings is really necessary. In case of order it is an absolute must to mention.

3. Divide C by P_R

4. Calculate the required shaft speed as shown

$$n = \frac{v \cdot 6 \cdot 10^4}{h_{\max}}$$

5. Determine the operational life in hours from the nomogram.

Example 1	Example 2
ARG 3-30-2 VCRF Speed 0.9 m/sec. Standard thrust F = 260 N	ARG 3-30-2 VCRF Speed 0.9 m/sec. Reduced thrust F = 200 N
1. C ₁ = 16,800	C ₁ = 16,800
2. P _R = 5 · 260 N = 1,300 N	P _R = 5 · 200 N = 1,000 N
3. $\frac{C_1}{P_R} = \frac{16,800}{1,300} = 12.92$	$\frac{C_1}{P_R} = \frac{16,800}{1,000} = 16.8$
4. $n = \frac{0.9 \cdot 6 \cdot 10^4}{25} = 2,160$ rpm	$n = \frac{0.9 \cdot 6 \cdot 10^4}{25} = 2,160$ rpm
5. L _{10h} = 16,500 Hours of operation	L _{10h} = 35,000 Hours of operation

Nomogram

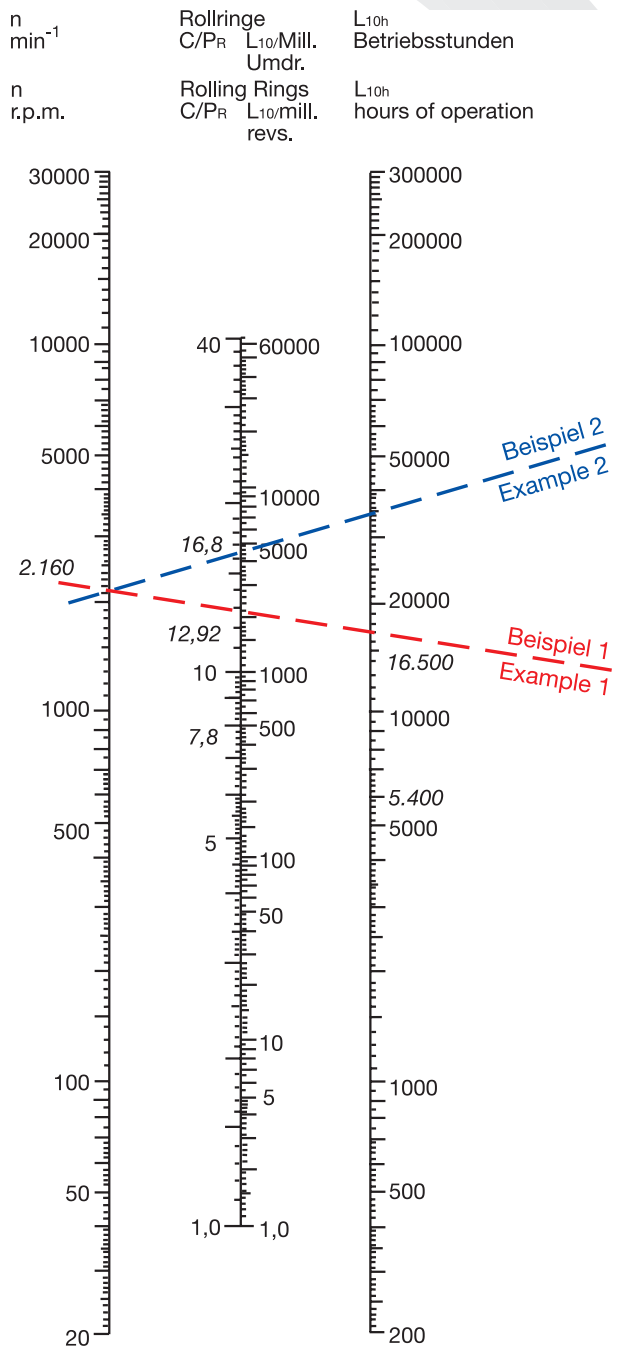

To make a selection for an application the data of application questionnaire 03e are required.

Operational guide

Security advice: the movements of the traverse drive can crush. It has to be protected against contact just like the rotating shaft.

1. Shaft material

1.1. Basic requirements

Uhing Linear Drives should only be used in conjunction with steel shafts manufactured from induction surface hardened, ground and finished bar of the following quality, minimum:

- surface hardness: 50 HRC
- tolerance on diameter: h6
- out of roundness: maximum one half of the diameter variation permitted by ISO tolerance h6
- true running tolerance (DIN ISO1101): ≤ 0.1 mm/m

1.2. Uhing precision shaft

Standard:

Material Cf 53, Mat.-No. 1.1213 induction surface hardened, 60-64 HRC

Rust and acid resistant:

Material X 90 CrMoV 18 Mat.-No. 1.4112 induction surface hardened, 52-56 HRC

- all ground and superfinished
- surface roughness: mean value (DIN 4768 T.1) $R_a: \leq 0.35$ μm
- tolerance on diameter: h6
- out of roundness: maximum one half of the diameter variation permitted by ISO tolerance h6
- true running tolerance (DIN ISO 1101): ≤ 0.1 mm/m

1.3. Uhing precision shafts with enhanced true running tolerance

Available in the above styles, but - true running tolerance (DIN ISO 1101): ≤ 0.03 mm/m

1.4. Leading end chamfer

The leading end of the shaft should be chamfered to avoid damage to the Rolling Rings when screwing the unit onto the shaft.

The following method should be followed to facilitate the screwing of the shaft into the unit:

For units not having a pressure screw (KI and types RG 4-15/20/22/30-2) the entry side for the shaft is not specified.

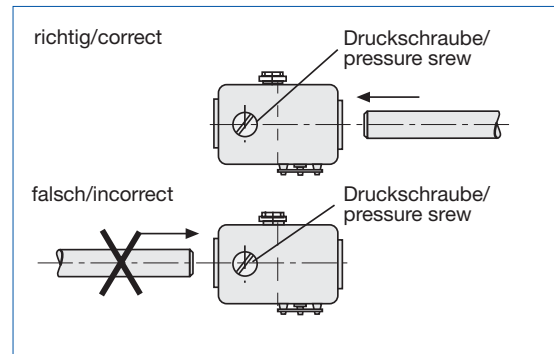
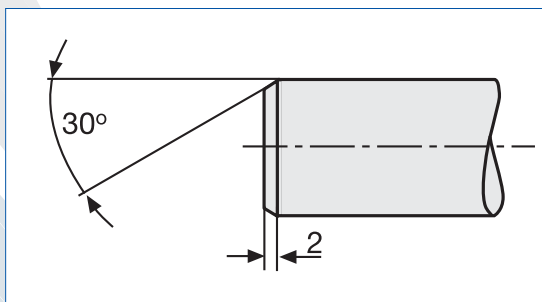

2. Shaft rotation

The mechanical reversal of the Rolling Ring Drive is related to the direction of shaft rotation. It will operate only when the rotation is as specified in the order (except for feature **D, N and RGK types**).

When changing the direction of rotation, the pitch symmetry must be checked and adjusted if necessary (see Operating Instructions 05e).

3. Reversal

3.1. Instantaneous reversal (Feature M)

Mode of operation: on making contact with a traverse stroke limiting endstop, the torsion springs in the reversal mechanism charge, trigger and fire the reversal once the throwover position has been reached.

For the reversal mechanism to operate, a minimum distance of travel approximately equivalent to the diameter of the shaft (dependent of the pitch setting) is required. The reversal time is also pitch related (see Fig. 2, page 20). Consequently, as the pitch is increased, there is a slight increase in the traverse stroke length (and a decrease if the pitch is reduced).

Differences in the stroke length also result when the speed of a unit, the pitch of which remains unaltered, is varied by significantly changing the shaft speed.

Drive speed increases = increase in length of stroke,
Drive speed decreases = decrease in length of stroke.

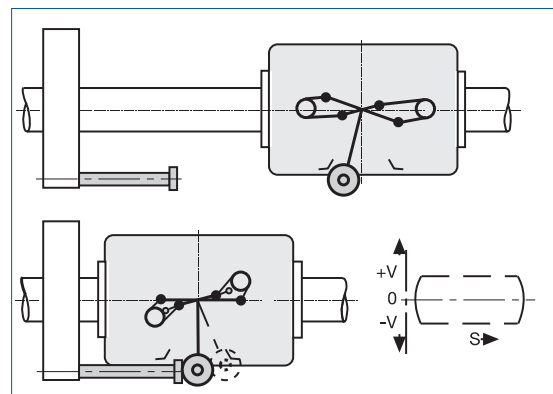

3.2. Reversal slowdown (Feature V)

Mode of operation: just prior to the reversal point an additional lever, which terminates in a contact bearing, makes contact with a V-shaped slowdown cam which causes it to swivel. This swivel action serves to reduce the unit's pitch as it approaches the reversal point such that the instantaneous reversal which follows is at a greatly reduced traverse speed.

This reversal slow-down makes higher traverse speed and/or greater forces possible.

The reversal slowdown is predominantly related to distance, changes in pitch do not effect the length of traverse stroke.

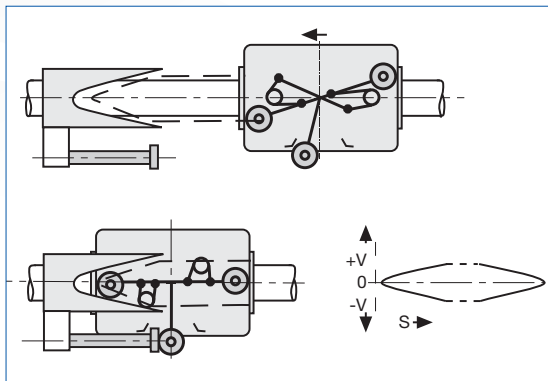

4. Pitch setting

The pitch is the distance travelled per revolution of the shaft. With a Uhing Rolling Ring Drive, this is variable between "1" and maximum "10". The pitch can be set either when the unit is in motion or stationary.

The following pitch setting possibilities are available: Kinemax and RGK: self retaining knob for infinite variability.

Feature C: 100/50 pitch selection scale covering the full pitch range.

Feature S: Set screws for the infinitely variable setting of the pitch in each direction.

Feature Z: Worm gear drive for infinitely variable pitch setting. Remote control from one of the end bracket positions possible.

Note: With the exception of S type units, the pitch is generally set to be the same for both directions of travel. The difference in pitch in the two directions (symmetry) is factory set not to exceed 2.5%, for RGK types not to exceed 5%.

5. Separately carried additional loads

If Rolling Ring Drives are used to move separately carried masses, allowance should be made in the coupling to compensate for any misalignment between the drive shaft and the carriage.

It should be additionally ensured that the distance between the point of connection and the unit is as short as possible, as twisting moments affect the thrust produced.

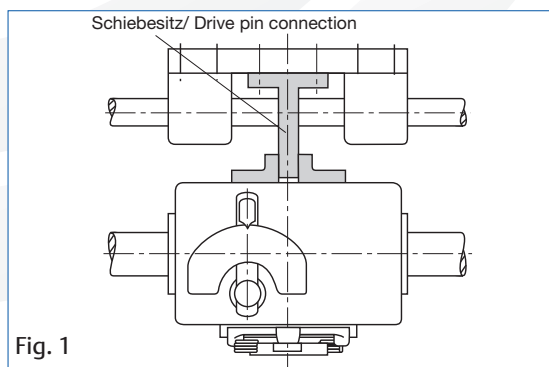
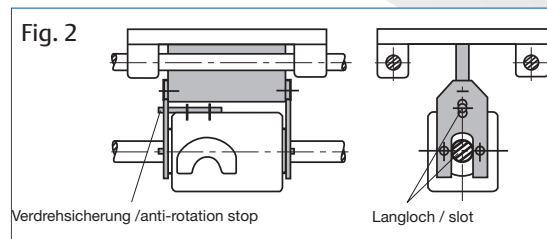
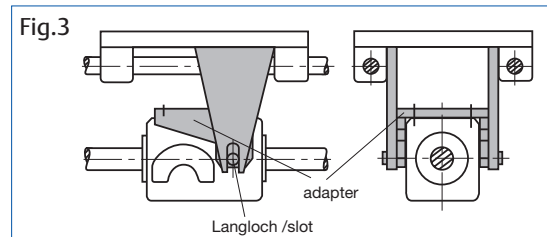

Fig. 1

Optimum couplings are twist-free as shown in Fig. 2 and 3.



Coupling connection at end of unit



Coupling connection at side of unit

6. Vertical applications or one-sided axial load

Attention should be given to the direction of the applied load and the position of the pressure setting screw so as to avoid a drop in thrust efficiency (except with KI 3-15-6, RGK-types, RG 4-15/20/22/30-2). In the arrangement illustrated, there is an increase in thrust when unit is moving up the shaft.

Please contact us. We would be pleased to advice you.

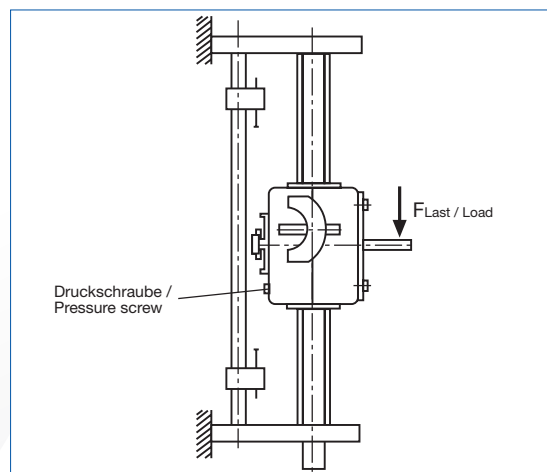

In applications using units with a free-movement-lever, care must be taken before operating it to ensure that the load can not drop in an uncontrolled way - injury could result.

7. Stopping on a rotating shaft

Rolling Ring Drives fitted with slowdown cams (type V) or a control lever (H or K) can, with appropriate control, be brought to a standstill (pitch setting "0") without the need to stop the shaft. This could be necessary if the drive is being used as a feed mechanism and is required to wait for a start signal at one or both ends of its traverse stroke.

Intermediate stop positions between the end stop positions are also possible. If positional accuracy in excess of ± 0.5 mm is acceptable, slowdown cams are adequate for the purpose. Otherwise, if accuracy better than ± 0.5 mm is sought, a control lever should be used.

To protect the condition of the shaft, we recommend that the drive to the shaft be switched out if the standstill period exceeds 5 sec. at full rated thrust. The standstill time can be extended if the shaft speed is low or the thrust is reduced. Please direct related enquiries to the supplier.

8. Traversing characteristics

By using a lever, the end of which is in the form of a roller which makes contact with cams arranged along the length of the traverse stroke, the pitch - and with it the speed - can be matched to the most varied requirements, the distances travelled being exactly repeatable.

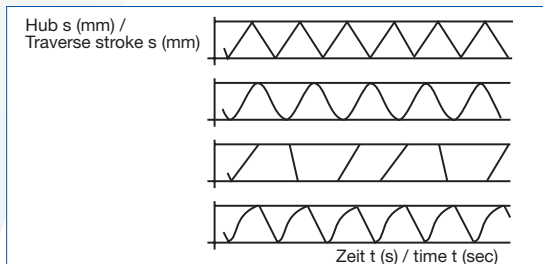

9. Synchronization of processes

Drives fitted with set screws (type S) offer the possibility of exactly relating the speed to that of already existing processes, e.g. synchronization of a travelling cutting head in cutting operations involving continuously fed materials. If the Uhing shaft and the material feed have a common drive, synchronization is maintained even if the overall material speed varies.

10. Operating temperature

Suitable for a temperature range of -10° to $+80^{\circ}$ C (RGK to $+50^{\circ}$ C). Special styles available for other temperatures on request.

11. Maintenance

Shaft: MoS2 free ballbearing greases can be used, e.g. SKF Alfalub LGMT, Esso Beacon EP1...3.

Procedure:

Clean the shaft and spread the grease with a rag as thin as possible.

Lubricate the reversal mechanism, particularly the springs, with high viscosity machine oil (SAE 90).

Frequency:

Monthly, shorter intervals are recommended e.g. where a unit is required to be stationary on a rotating shaft, it is working in shifts, where it operates under extremely dusty conditions, at temperatures over 80° C.

Technical alterations are reserved.



Worldwide

The addresses of our agencies are available in the internet:
www.uhing.com

Joachim Uhing GmbH & Co. KG
Konrad-Zuse-Ring 20
24220 Flintbek, Germany
Telefon +49 (0) 4347 - 906-0
Telefax +49 (0) 4347 - 906-40
e-mail: sales@uhing.com
Internet: www.uhing.com



RG 07 e 01/2024