



Timing Belt Drive

AZ

Operating Instructions



Legal notice

Copyright® by Joachim Uhing GmbH & Co. KG, Kieler Straße 23, D-24247 Mielkendorf, Germany. Joachim Uhing GmbH & Co. KG is the copyright holder. All rights reserved.

The products described in this manual are the Joachim Uhing GmbH & Co. KG company's own products. The current Operating Instructions must not be copied without express approval from Joachim Uhing GmbH & Co. KG as per the legal copyright regulations. The exception does not extend to manufacturing copies for other users. By law, the term "copying" includes translating into another language or another format.

On receipt of data storage devices, the Recipient shall acquire a personal, non-transferable licence to use the Operating Instructions saved on them in association with the product supplied by Joachim Uhing GmbH & Co. KG.

Joachim Uhing GmbH & Co. reserves the right to make amendments to its products that act as technological developments at any time and without prior notice. These amendments are not necessarily documented for each individual case.

Manufacturer

Address: Joachim Uhing GmbH & Co. KG, Kieler Straße 23, D-24247 Mielkendorf, Germany.

Telephone: +49 4347 906-0

Fax: +49 4347 906-40

E-mail: info@uhing.com

Internet: <http://www.uhing.com>

Technical information or support:

Customer services

Telephone: +49 4347 906-0

Fax: +49 4347 906-40

E-mail: sales@uhing.com

Contact details for agencies outside of Germany: <http://www.uhing.com/de/informationen/vertrieb/>

Contents

1.	General.....	1
1.1.	AZ timing belt drives	1
1.1.1.	Identifying the AZ timing belt drives.....	3
1.2.	Proper use	3
1.3.	Improper use.....	3
1.4.	Product guarantee	3
1.5.	Symbols and their meaning	4
1.5.1.	General symbols.....	4
1.5.2.	Safety symbols	4
1.6.	Organisational measures.....	5
1.6.1.	Requirements of the operating staff	5
1.7.	Disassembly	5
1.8.	Disposal	5
2.	Transportation and storage	6
2.1.	Measures relating to transportation	6
2.2.	Permitted ambient temperature	6
2.3.	Items included and checking items supplied	6
3.	Safety information for installation and operation	7
4.	Installation	9
4.1.	Overview depiction	9
4.2.	Prerequisites for installation	10
4.3.	Procedure when installing	11
4.3.1.	Fitting the timing belt drive.....	11
4.3.2.	Fitting the payload	12
5.	Operation.....	13
5.1.	Prerequisites for trouble-free operation	13
5.2.	First use	13
6.	Maintenance and repairs.....	14
6.1.	Maintenance	14
6.2.	Adjusting the slide guide's play	14
6.3.	Adjusting the roller guide's play.....	15
6.4.	Repair	16
6.5.	Replacement parts.....	16

7.	Technical Appendix	17
7.1.	Naming logic	17
7.2.	Selection	18
7.3.	Type reference Timing Belt AZ	19
7.3.1.	Style AZ 1010	19
7.3.1.1.	Technical Details	19
7.3.1.2.	Special features	19
7.3.1.3.	Dimensions style AZ 1010	20
7.3.1.4.	Load / Moments	20
7.3.1.5.	Moments style AZ 1010	21
7.3.2.	Style AZ 1040	22
7.3.2.1.	Technical Details	22
7.3.2.2.	Special features	22
7.3.2.3.	Dimensions style AZ 1040	23
7.3.2.4.	Load / Moments	23
7.3.2.5.	Moments style AZ 1040	24
7.3.2.6.	Motor positions style AZ 1040	25
7.3.3.	Style AZ 2000	28
7.3.3.1.	Technical Details	28
7.3.3.2.	Special features	28
7.3.3.3.	Dimensions style AZ 2000	29
7.3.3.4.	Load / Moments	29
7.3.3.5.	Moments style AZ 2000	30
7.3.4.	Style AZ 2001	31
7.3.4.1.	Technical Details	31
7.3.4.2.	Special features	31
7.3.4.3.	Dimensions style AZ 2001	32
7.3.4.4.	Load / Moments	32
7.3.4.5.	Moments style AZ 2001	33
7.3.5.	Style AZ 2004	34
7.3.5.1.	Technical Details	34
7.3.5.2.	Special features	34
7.3.5.3.	Dimensions style AZ 2004	35

7.3.5.4.	Load / Moments	35
7.3.5.5.	Moments style AZ 2004	36
7.3.6.	Style AZ 2005	37
7.3.6.1.	Technical Details	37
7.3.6.2.	Special features	37
7.3.6.3.	Dimensions style AZ 2005	38
7.3.6.4.	Load / Moments	38
7.3.6.5.	Moments style AZ 2005	39
7.4.	Accessories	40

1. General

These operating instructions apply to all currently available models of the AZ timing belt drive with its different items of equipment.

The operating instructions give the user important general information about the AZ timing belt drives and information on storage and transportation, installation, commissioning, maintenance and servicing.

Users should read through the operating instructions carefully and pay attention to all items of information and advice.

1.1. AZ timing belt drives

Uhing timing belt drives consist of a rigid, torsion-resistant aluminium profile. Integrated into the carrier profile are several T-grooves. They facilitate variable usage and make assembly easier. In addition, it is possible to slide in slot nuts.

The timing belt drive translates the rotating input movement into linear movement. Power is transferred from the timing belt to the load carrier via the belt joint mounted on the latter. The carrier, with roller or slide bearings, moves back and forth in accordance with the input rotational direction.

The AZ timing belt drives make little noise.

The timing belt drives are designed only for operation in enclosed spaces at normal indoor temperatures.



Illustration 1: Timing belt drive AZ 1010

Fitted with sensors

The AZ timing belt drive can be fitted at the factory with two contactless inductive sensors. The sensors, which can be moved lengthways, are arranged on slots nuts in a profile groove.

Fitted with motor

The AZ timing belt drive can also be fitted at the factory with a motor.

AZ timing belt drives' CAD data

To make your work easier, we make our drives' CAD data available to you online for download.



Note: The AZ timing belt drives are subject to technical modifications at any time.

1.1.1. Identifying the AZ timing belt drives

Each AZ timing belt drive has a type plate fixed to it showing

- model name (model) and
- product number (prod. no.).



Note: Using the product number it is possible to identify every AZ timing belt drive unambiguously. When contacting the manufacturer with any questions about the product, please have the product number to hand.

1.2. Proper use

All models of the AZ timing belt drive are intended solely for use in industrial applications.

1.3. Improper use

Any use other than in an industrial application is improper.

1.4. Product guarantee

The guarantee on all models of the AZ timing belt drive conforms with the current VDMA provisions.



Note: Any retightening of the timing belt during the guarantee period immediately invalidates the guarantee!

1.5. Symbols and their meaning

1.5.1. General symbols



Note: This symbol is used to indicate information that requires particular attention.



Tip: This symbol is used to provide tips and useful information.

1.5.2. Safety symbols



This symbol warns of danger.



This symbol warns of damage.

Danger level word / colour	Significance if ignored
DANGER	Leads to serious injury.
CAUTION	Can lead to damage.

1.6. Organisational measures

1.6.1. Requirements of the operating staff

It is a prerequisite of using AZ timing belt drives that staff carefully read the operating instructions. All staff using AZ timing belt drives should have a basic knowledge of technical assembly. No special training is required. However, Joachim Uhing GmbH & Co. KG recommends having staff trained for their work with AZ timing belt drives. Dates for training sessions can be arranged with the company's sales department or our agent in your country.

1.7. Disassembly

To disassemble an AZ timing belt drive, proceed as follows:

1. Remove the two screws for adjusting belt tension.
2. If there is a covering cap on the load carrier, take this off.
3. Draw the timing belt along with the plates out of the load carrier profile.
4. Remove the profile plate.
5. Pull the timing belt out over the cogwheels.
6. Disassemble the head ends and all other components.

1.8. Disposal

Dispose of aluminium parts in the local disposal company's aluminium waste, steel parts in their scrap steel waste and plastic parts in their recyclable waste container.

2. Transportation and storage

2.1. Measures relating to transportation

 DANGER	There is a risk of injury if carriers are transported without being firmly secured.
	<p>If not secured during transportation, carriers can bump against a bearing mount. There is a risk of serious injury to hands or fingers.</p> <ul style="list-style-type: none">➤ Secure the carrier prior to transporting the AZ timing belt drive. For example, wrap it in tear-resistant plastic film and then secure it with well-gripping, tear-proof adhesive tape.

Depending on the size and weight of your AZ timing belt drive, several people will be needed to transport it.

2.2. Permitted ambient temperature

AZ timing belt drives

- Must be stored in cool, dry conditions, protected from ultraviolet light and sources of corrosion
- May be stored only for a short time
- May be stored only in ambient temperatures of -10°C to +80°C.





If you want to store the unit at below -10°C or above +80°C, please consult the manufacturer.

2.3. Items included and checking items supplied

The AZ timing belt drive is supplied fully assembled. Check that the model name and product number on the type plate fixed to the unit matches your order details and the requirements for your intended use.

3. Safety information for installation and operation

 DANGER	There is a risk of injury if input torque is lost
	<p>The AZ timing belt drive has no brake. If input torque is lost, the carrier can move freely. There is a risk of serious injury if, for instance, any finger or hand gets in between the right or left internal side of the bearing mount and the load carriers.</p> <ul style="list-style-type: none">➤ Fundamentally, therefore, never put your hand into the area between the right or left internal side of the bearing mount and the load carrier!➤ By using motors with an integrated spring-loaded holding brake or with a high level of inherent holding torque, it is possible to achieve self-locking of the whole system.

 DANGER	Risk of injury when installing vertically
	<p>When installation is in a vertical position, it is possible for loads that the carriers are intended to carry to fall off. This is particularly the case in the event of a loss of power or if the timing belt breaks. There is a risk of serious injury and of damage.</p> <ul style="list-style-type: none">➤ Ensure that motors have a spring-loaded brake that does not depend on a live current.➤ Fit other appropriate safety measures, such as safety latches or end-stop buffers.

 DANGER	Risk of injury when timing belt drive is in operation
	<p>When the timing belt drive is running, there is a risk of serious injury if, for instance, any finger or hand gets in between the right or left internal side of the bearing mount and the load carriers.</p> <ul style="list-style-type: none">➤ Keep away from the timing belt drive when it is in operation.➤ Fundamentally, never put your hand into the area between the right or left internal side of the bearing mount and the load carrier!

 DANGER	Risk of injury caused by objects moving at unexpected speed
	<p>Objects moving at unexpected speed can cause injury or damage.</p> <ul style="list-style-type: none">➤ When taking it into operation, have the drive motor run only very slowly at first.



CAUTION

Contact with oil, grease or vapours that dissolve grease can cause damage

The AZ timing belt drive must not come into contact with any oil, grease or grease-dissolving vapours. Any such contact may cause damage to the timing belt drive or to some of its parts.

If in your application there is a risk of the AZ timing belt drive coming into contact with oil, grease or vapours that dissolve grease, please consult the manufacturer.

4. Installation

4.1. Overview depiction

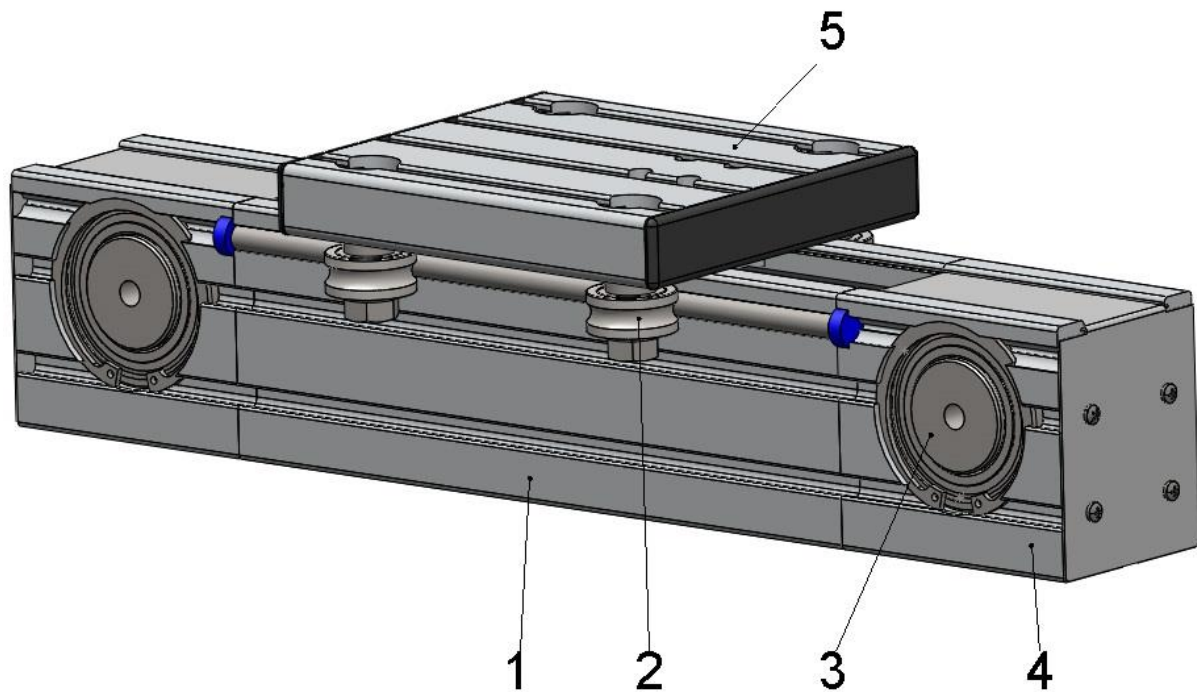

Illustration 2: Overview depiction of the AZ 1040 timing belt drive

- 1 Profile housing
- 2 Guide rollers
- 3 Cogwheel for drive shaft
- 4 Bearing mount
- 5 Load carrier

4.2. Prerequisites for installation



Read and take note of the safety information in section 3. Safety information for installation and operation.

- Take into account the statutory provisions that apply to the intended place of use, such as:
 - Regulations and standards
 - The rules of inspecting bodies and insurers
 - National regulations
- Remove all precautionary transportation fittings and check that the timing belt drive is in perfect condition.
- Use the AZ timing belt drive only in its original condition. Do not make any unauthorised modifications.
- Take into account the ambient conditions at the place of use.
- Compare the thresholds in this case of use; see section 7. Technical data.



Only by adhering to the loading limits is it possible to operate the product in accordance with the relevant safety guidelines.

- Take account of the tightening torques' tolerance.



Unless otherwise indicated, the tolerance is $\pm 20\%$.

- Take note of the thresholds for levels of force, torque and speed.



In section 7. 'Technical Appendix' you will find the relevant data for all models of the AZ timing belt drive.

- Select a suitable drive motor for the timing belt drive.



If you are uncertain, please consult the manufacturer or the company's agent in your country.

4.3. Procedure when installing

Secure the timing belt drive only as described in the following assembly instructions!

4.3.1. Fitting the timing belt drive

The fitting process is shown using an AZ 2000 timing belt drive as an example.

1. Fix the profile housing to a suitable support.
2. During the fitting process, be sure to avoid any tension or bending.
3. When building up the timing belt drives as a portal system, make sure that the axes are aligned parallel to one another.
4. Be mindful of the aluminium profile's maximum deflection. You will find information on this in section 7. 'Technical Data'.
5. Using tightening torque of 5Nm, evenly tighten the M5 securing screws.

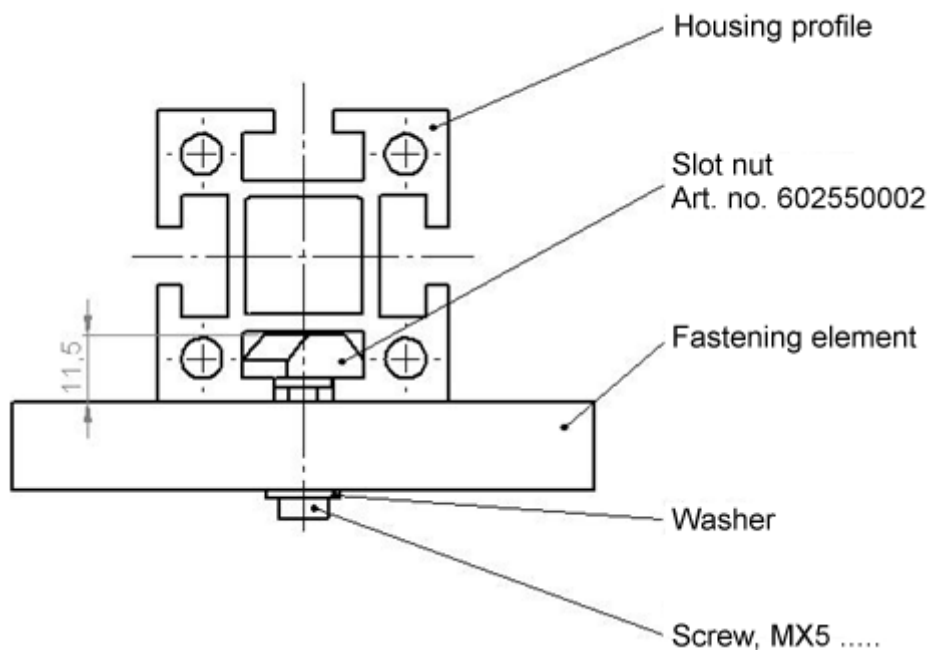

Illustration 3: Securing timing belt drive using M5 slot nut

Leave the fully assembled timing belt drive unaltered.



The timing belt tension must not be changed! If you change the timing belt tension during the guarantee period, you lose your right to any claim under the guarantee.

4.3.2. Fitting the payload

1. Note the maximum screw-in depth of 18mm for the securing screws.
2. Using torque of 9 Nm, evenly tighten the securing screws.
3. Be mindful of the maximum load!
You can find details of your timing belt drive's maximum load as follows:
 - in section 7.3 'AZ Timing Belt Drive Model Range', refer to the sub-section relating to the model range that you are using.
 - In the associated 'Loads' section you will find a table.
 - Column 'Fz' of this table contains specification 'N' relating to the load of the timing belt drive concerned.
4. Make sure that during operation the fitted payload does not bump anywhere against anything.
5. Position the payload on the load carrier in such a way that the resultant overturning torque on the carrier remains as low as possible.

5. Operation

5.1. Prerequisites for trouble-free operation



Read and take note of the safety information in section 3 'Safety Information for Installation and Operation'.



The timing belt tension must not be changed! If you change the timing belt tension during the guarantee period, you lose your right to any claim under the guarantee.



Improper use of the AZ timing belt drive can lead to malfunctions.



All models of the AZ timing belt drive may be operated at ambient temperatures of -10°C to $+80^{\circ}\text{C}$. If you want to operate the unit at below -10°C or above $+80^{\circ}\text{C}$, please consult the manufacturer.

5.2. First use

1. Let the drive motor briefly warm up.
2. Check the direction of movement.
3. Initiate a control run at low speed.
4. Increase the speed to the requirements of your application.
5. Check whether the timing belt drive is fulfilling your application's requirements.



Note: During operation, loads being transported by the load carriers may cause vibrations, which in turn can affect the timing belt drive.

If you are in any doubt as to whether the vibration caused by a load on the load carrier can damage the AZ timing belt drive, please consult the manufacturer.

6. Maintenance and repairs

6.1. Maintenance

- The AZ 2000 timing belt drive's slide guide requires no lubrication.
- The cogwheels' roller bearings have cover plates and their lubrication lasts for their full service life.
- It is fundamentally forbidden to retighten the timing belt.



Note: Any retightening of the timing belt during the guarantee period immediately invalidates the guarantee!

- Keep the timing belts free of any grease, oil or substances containing solvents.
- Keep the guide's slide surface clean at all times.
- If necessary, prevent the guides from getting dirty by structural means.
- Clean the guides using soft cloths and a cleaning agent that causes no harm to the materials.

6.2. Adjusting the slide guide's play

If after prolonged use of the AZ 2000 timing belt drive the slide guide's play becomes greater, the slide guide must be adjusted so that it again has no play. Proceed as follows:

1. Undo the hexagon nuts (4).
2. Evenly tighten the bolts (1) until primary tension is present again in the disc springs (3) and the track (2) is again lying free of any play on the profile.
3. Firmly tighten the counter-nuts.

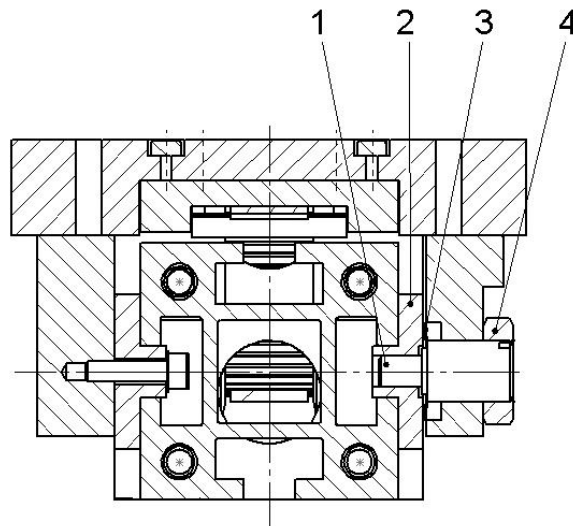

6.3. Adjusting the roller guide's play

If after prolonged operation of an AZ1010, AZ1040, AZ2001, AZ2004 or AZ 2005 timing belt drive the roller guide's play becomes greater, the roller guide must be adjusted so that it again has no play.

To do that, proceed as follows:

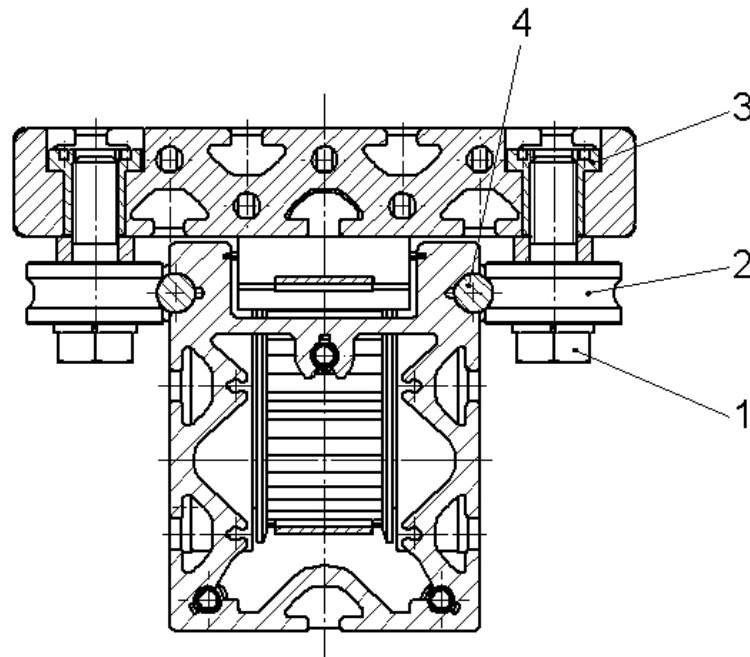

4. Undo the screws (1).
5. Using a face spanner, turn the eccentric tappet (3) until the rollers (2) lie on the round track (4) without any play.



Caution: The rollers (2) must lie on the round track (4) so firmly that no further turning by hand is possible.

6. Using the face spanner, hold the eccentric tappet (3) firm and fully tighten the screw (1).



Note: In some cases long use of the product may lead to the rollers and round tracks becoming worn. In this event, they must be replaced.

If it is not possible or expedient to do the repair at your own premises, please send the timing belt drive to the manufacturer or the company's agent in your country.

6.4. Repair

In the event of any fault in the functionality of your AZ timing belt drive or of any defect, please contact Joachim Uhing GmbH & Co. KG or the company's agent in your country.

Repairs may be carried out only by specialists authorised by the manufacturer.

If it is not possible or expedient to troubleshoot a fault or to do the repair at your own premises, please send the timing belt drive to the manufacturer or the company's agent in your country.

6.5. Replacement parts

Every component with which the AZ timing belt drive can be equipped can generally be replaced.

Replacement usually takes place at the manufacturer's premises. For this to be done, you can send the timing belt drive to the manufacturer or the company's relevant agent.

7. Technical Appendix

7.1. Naming logic

The names of AZ timing belt drives contain information about the model and its features.

Each timing belt drive's name is made up of a maximum of six fields. Fields 1 to 5 always contain information. Field 6 is filled only if the drive nut is equipped with a special feature.

Field	Meaning
1	Product code: A (drive; German: Antrieb)
2	Product code: Z (timing belt; German: Zahnriemen)
3	Design: 1010, 1040, 2000, 2001, 2004 or 2005
4	Timing belt model: 009MR3 for AZ1010 025MR5 for AZ 1040 and AZ 2004 015MR3 for AZ 2000 and AZ 2001 030MR8 for AZ 2005
5	Stroke length in millimetres: 0001 – 9999
6	X, if any customer-specific feature is integrated

Timing belt drive - AZ range nomenclature

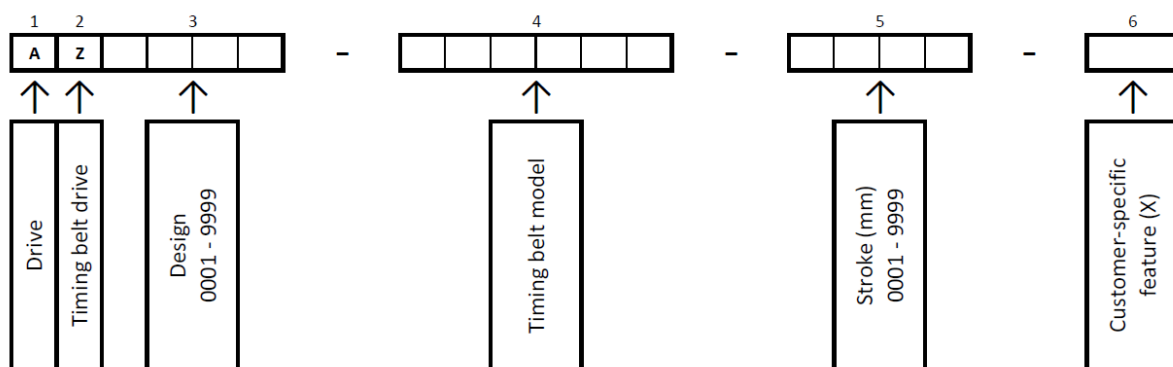

X = Motor, proximity switch, wiper, oiler, increased corrosion protection, special carrier, special timing belt or other feature by agreement

7.2. Selection

L_{Ges} = Stroke + width of carrier + end frames + safety allowance

Stroke = Max. working range

Max. travel = Stroke + safety allowance (standard = 20 mm or as required by customer)

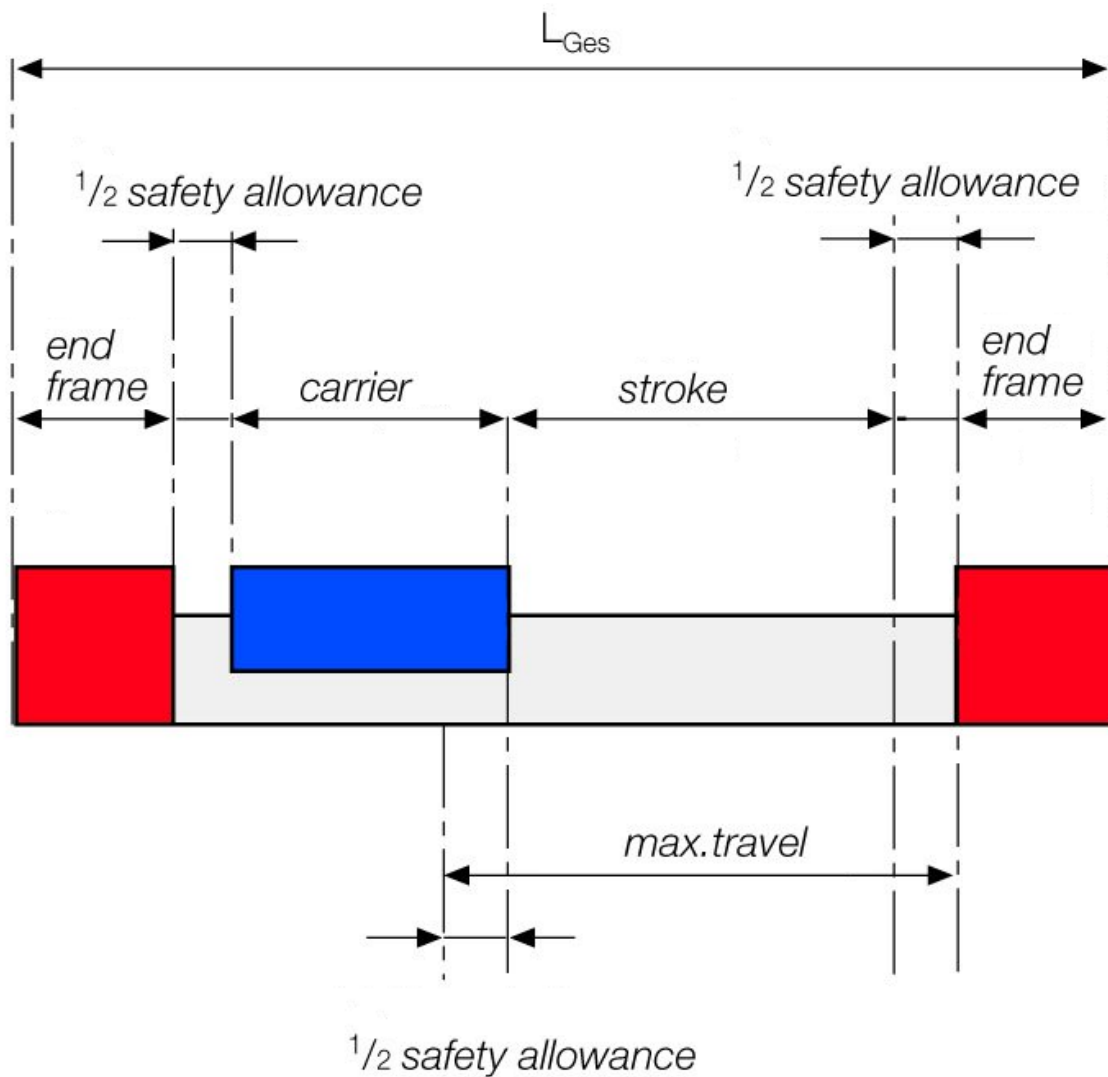

Note: The required braking or acceleration distances are a part of the stroke.

7.3. Type reference Timing Belt AZ

7.3.1. Style AZ 1010

Timing Belt	009MR3
Track: Round guide bars, protected against corrosion and hardened, mounted in AL-profile	X
Slide rails conjunction with AL-profile, adjustable to give zero play	–

7.3.1.1. Technical Details

Travel/revolution		81mm
Friction coefficient	μ	0.02
Mode of installation		any position
Speed of travel		max. 3,5 m/s
Idling torque	M0	0,1 Nm
Moment of inertia	Ix	6.639 cm ⁴
	Iy	10.546 cm ⁴
Moment of resistance	Wx	3.319 cm ³
	Wy	5.550 cm ³
Weight	m0 ¹⁾	1,0 kg
	m100 ²⁾	0,2 kg
	ms ³⁾	0,2 kg
Effective belt pulley diameter	d ₀	25,78 mm
Timing belt Neoprene with glass cord strengthener		type MR3
Timing belt Neoprene with steel cord strengthener		–
Width of timing belt		9,0 mm

¹⁾ Own weight of drive with length of stroke 0

²⁾ Wight per 100 mm length of stroke

³⁾ Weight of moving mass (carrier)

7.3.1.2. Special features

Motor	X
Proximity switch	X
Wipers	X
Combined lubrication and wiper attachment	X
Enhanced protection against corrosion	X
Covers	X
Carrier with non-standard fixing points	X
Motor connection plate	X

7.3.1.3. Dimensions style AZ 1010

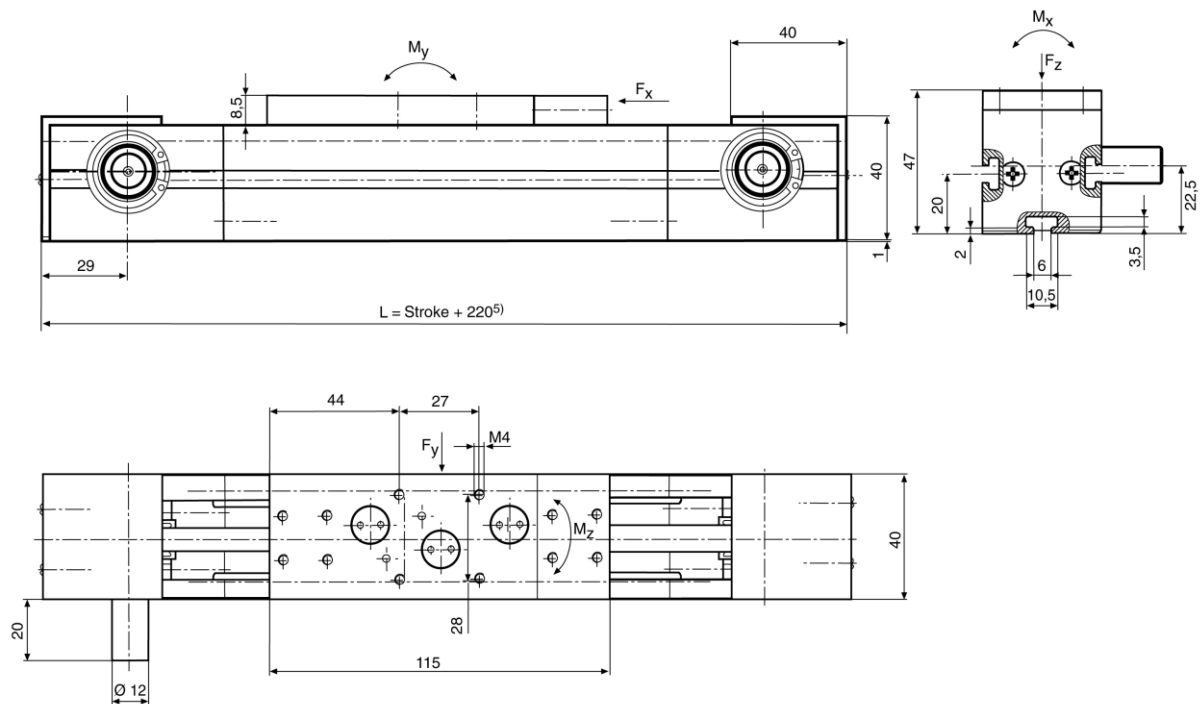

7.3.1.4. Load / Moments

F_x	F_y	F_z	M_x	M_y	M_z
300 N	120 N	146 N	1,8 Nm	2,3 Nm	4,7 Nm

All specifications are based on a running distance of 10.000 km.

7.3.1.5. Moments style AZ 1010

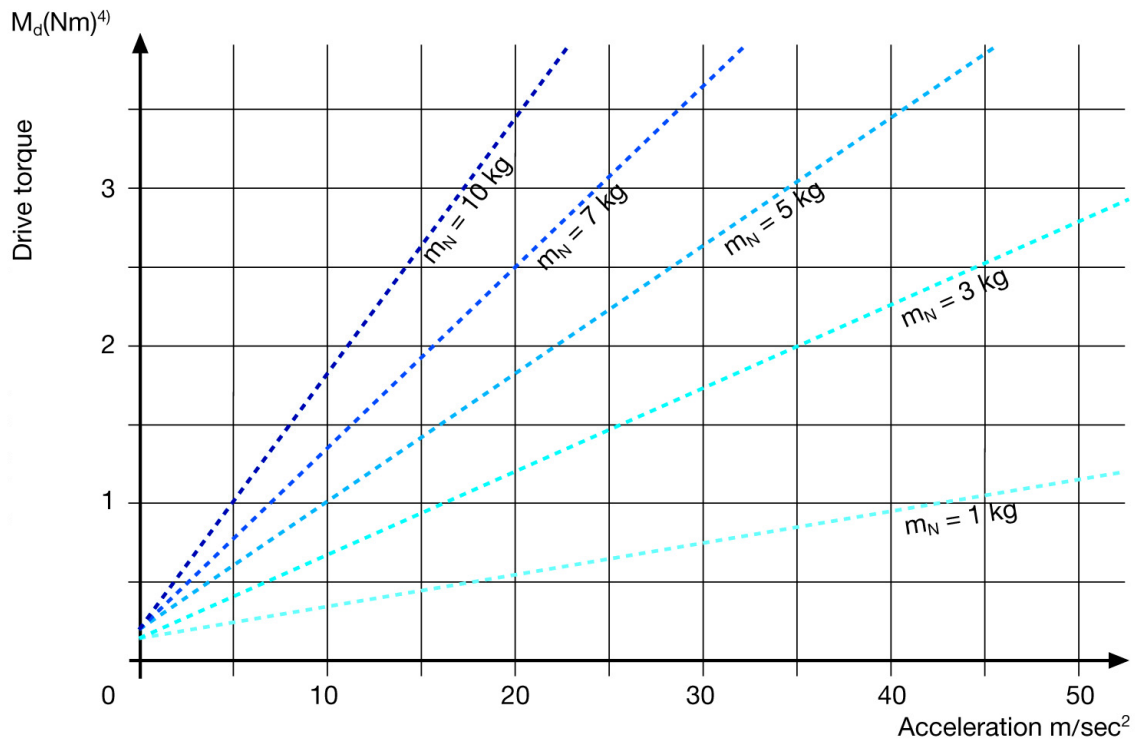

⁴⁾ Idling torque included

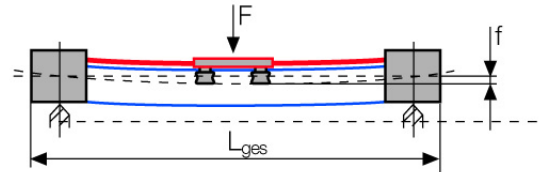
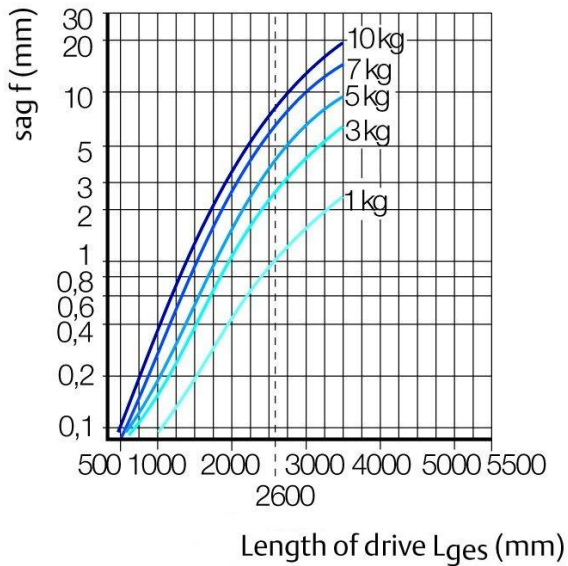

7.3.2. Style AZ 1040

Timing Belt	025MR5
Track: Round guide bars, protected against corrosion and hardened, mounted in AL-profile	X
Slide rails conjunction with AL-profile, adjustable to give zero play	–

7.3.2.1. Technical Details

Travel/revolution		200 mm
Friction coefficient	μ	0.02
Mode of installation		any position
Speed of travel		max. 5 m/s
Idling torque	M0	0,7 Nm
Moment of inertia	I _x	269 cm ⁴
	I _y	210 cm ⁴
Moment of resistance	W _x	53 cm ³
	W _y	52 cm ³
Effective belt pulley diameter	d ₀	63,66 mm
Timing belt Neoprene with glass cord strengthener		–
Timing belt Neoprene with steel cord strengthener		type MR5
Width of timing belt		25,0 mm

¹⁾ Own weight of drive with length of stroke 0

²⁾ Wight per 100 mm length of stroke

³⁾ Weight of moving mass (carrier)

7.3.2.2. Special features

Motor	X
Proximity switch	X
Wipers	X
Combined lubrication and wiper attachment	X
Enhanced protection against corrosion	X
Covers	X
Carrier with non-standard fixing points	X
Motor connection plate	–

7.3.2.3. Dimensions style AZ 1040

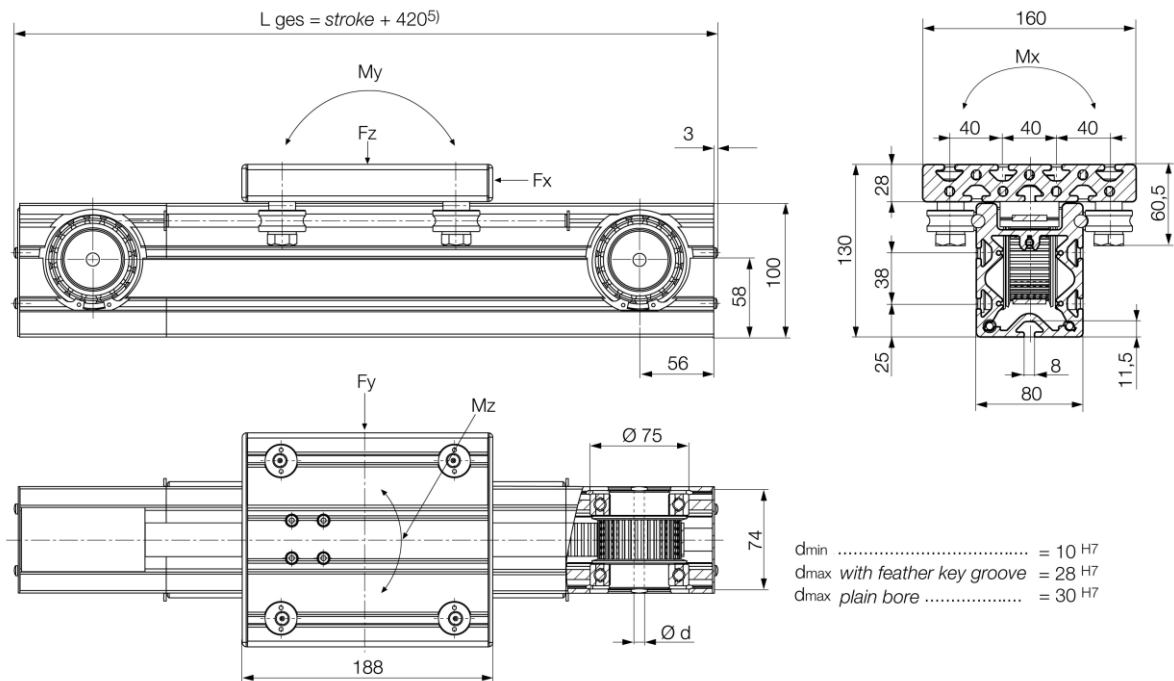

7.3.2.4. Load / Moments

F_x	F_y	F_z	M_x	M_y	M_z
1700 N	2000 N	1200 N	54 Nm	84 Nm	146 Nm

All specifications are based on a running distance of 10.000 km.

7.3.2.5. Moments style AZ 1040

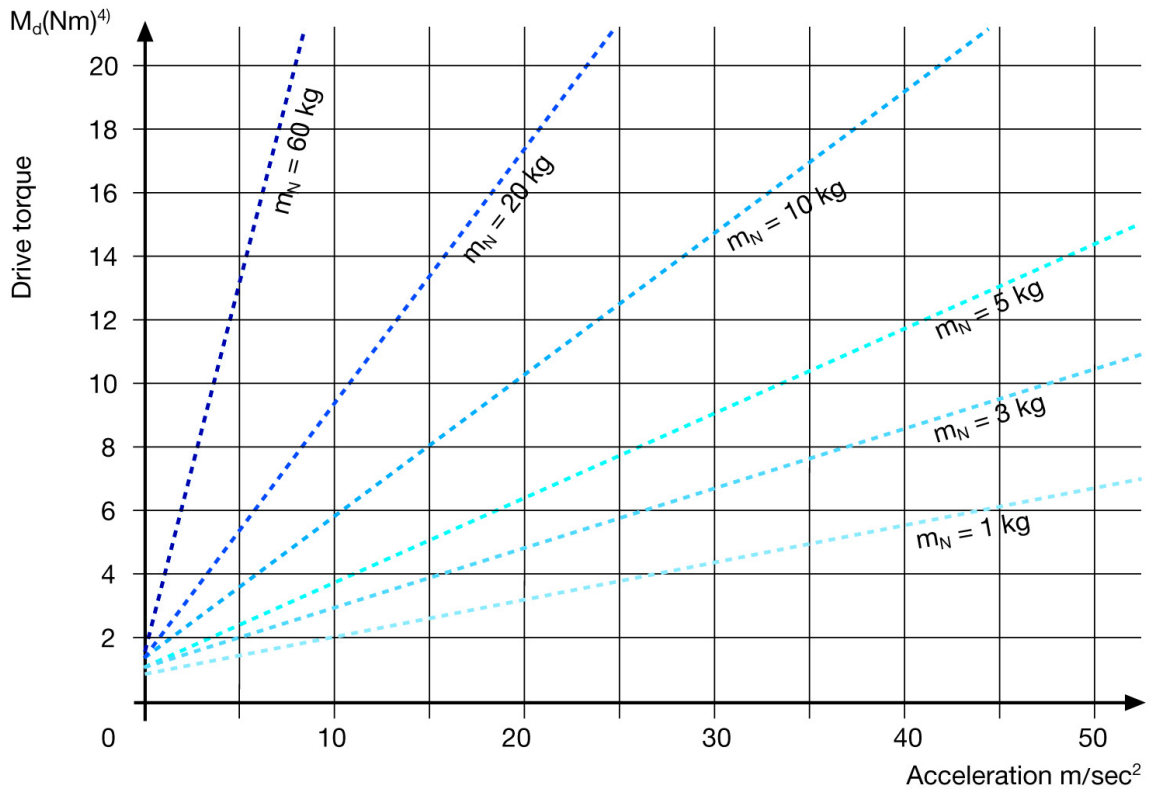

⁴⁾ Idling torque included

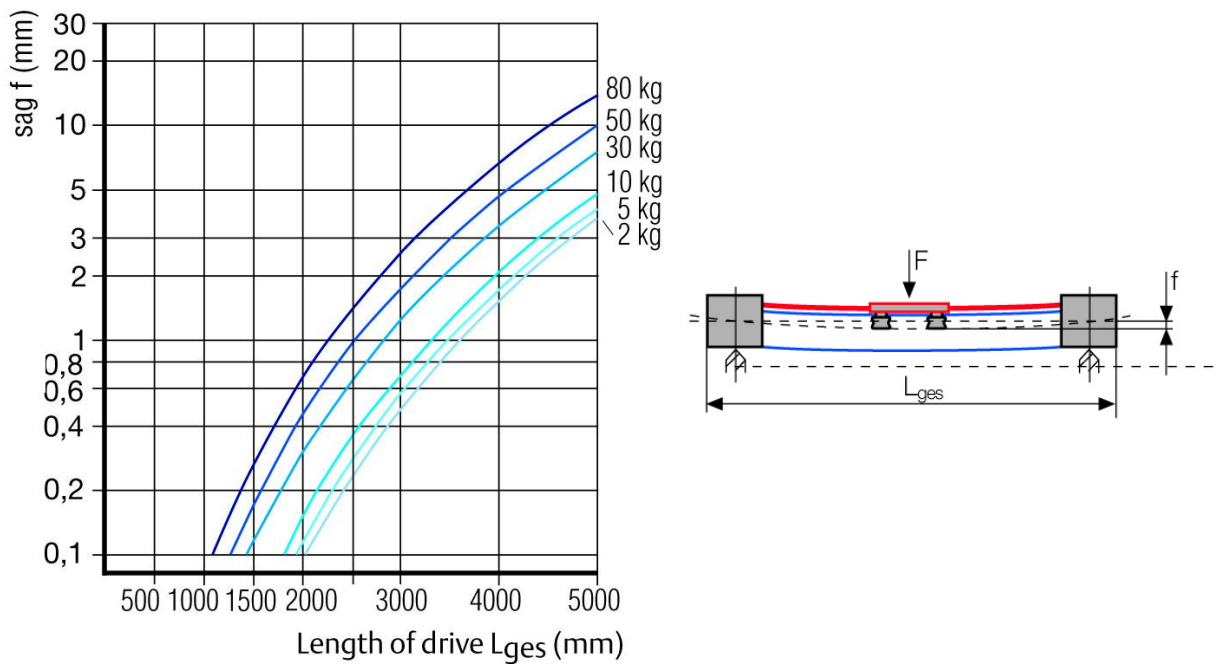

7.3.2.6. Motor positions style AZ 1040

Motor position A

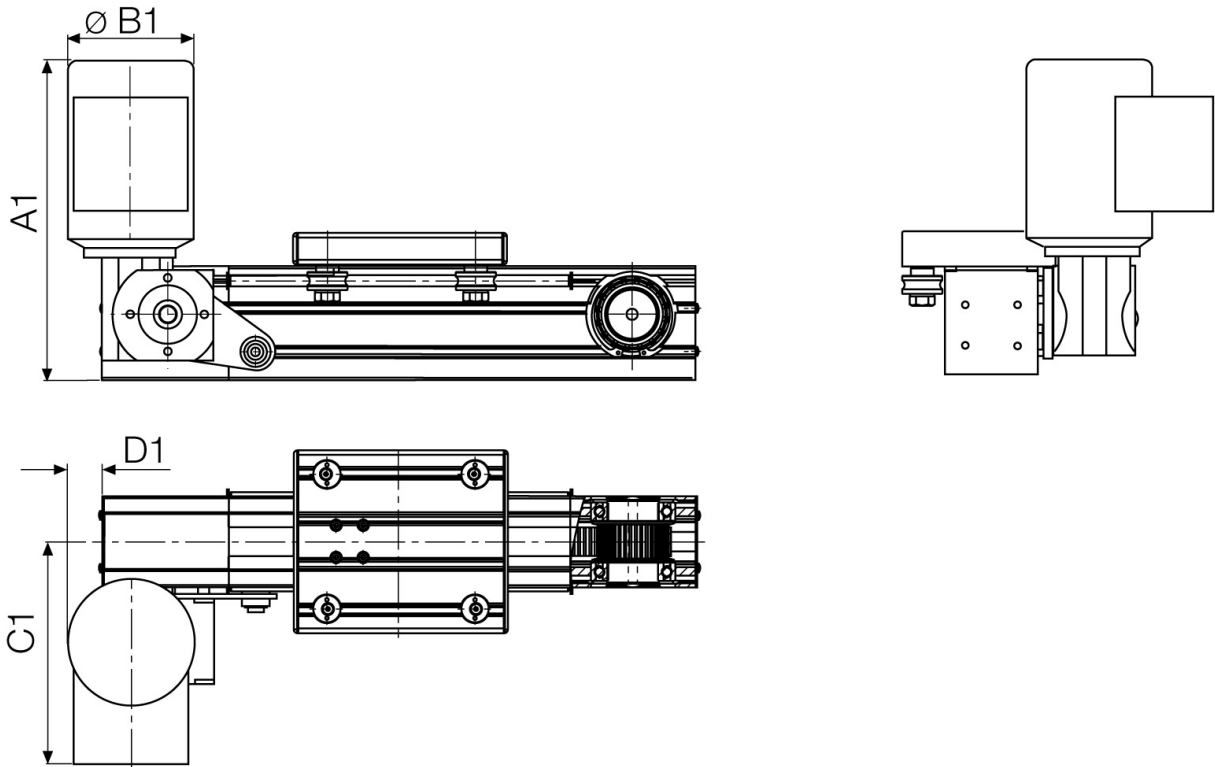

Dimensions	Type of motor		
	56	63	71
A1	285	305	330
ØB1	115	125	140
C1	200	205	215
D1	35	45	50

Drive data	Output torque	Drive power
20 min ⁻¹ – 857 min ⁻¹	10 Nm – 21 Nm	0,07 KW – 1,03 KW

Motor position B style AZ 1040

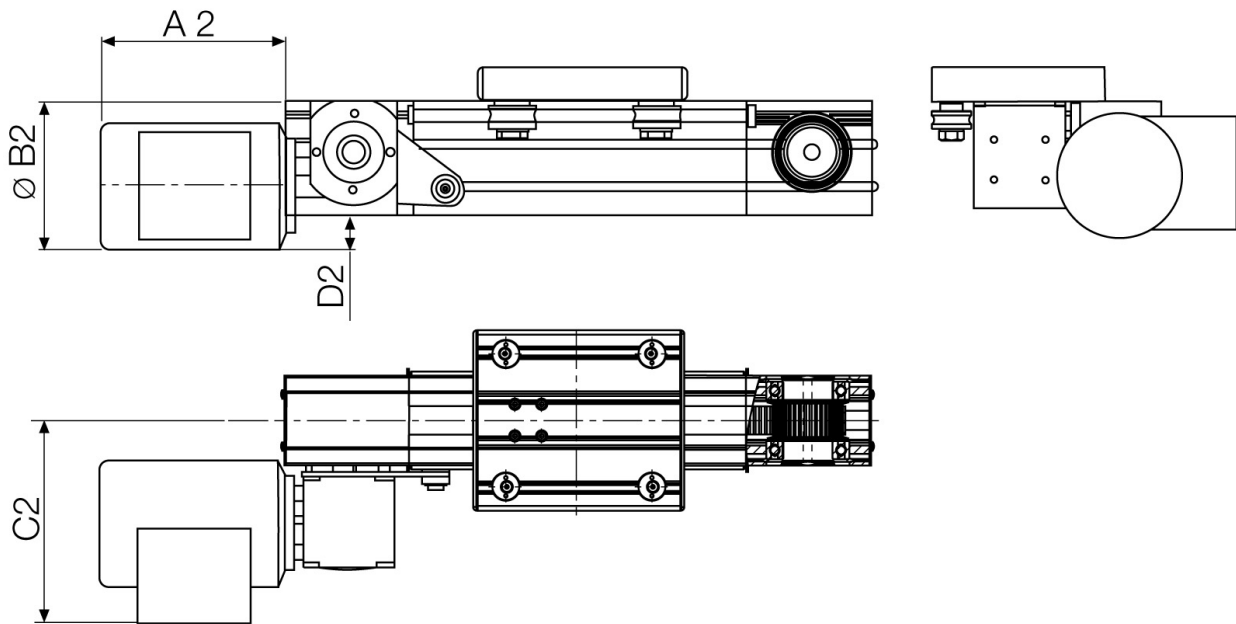

Dimensions	Type of motor		
	56	63	71
A2	170	190	215
ØB2	115	125	140
C2	200	205	215
D2	35	40	50

Drive data	Output torque	Drive power
20 min ⁻¹ – 857 min ⁻¹	10 Nm – 21 Nm	0,07 KW – 1,03 KW

Motor position C style AZ 1040

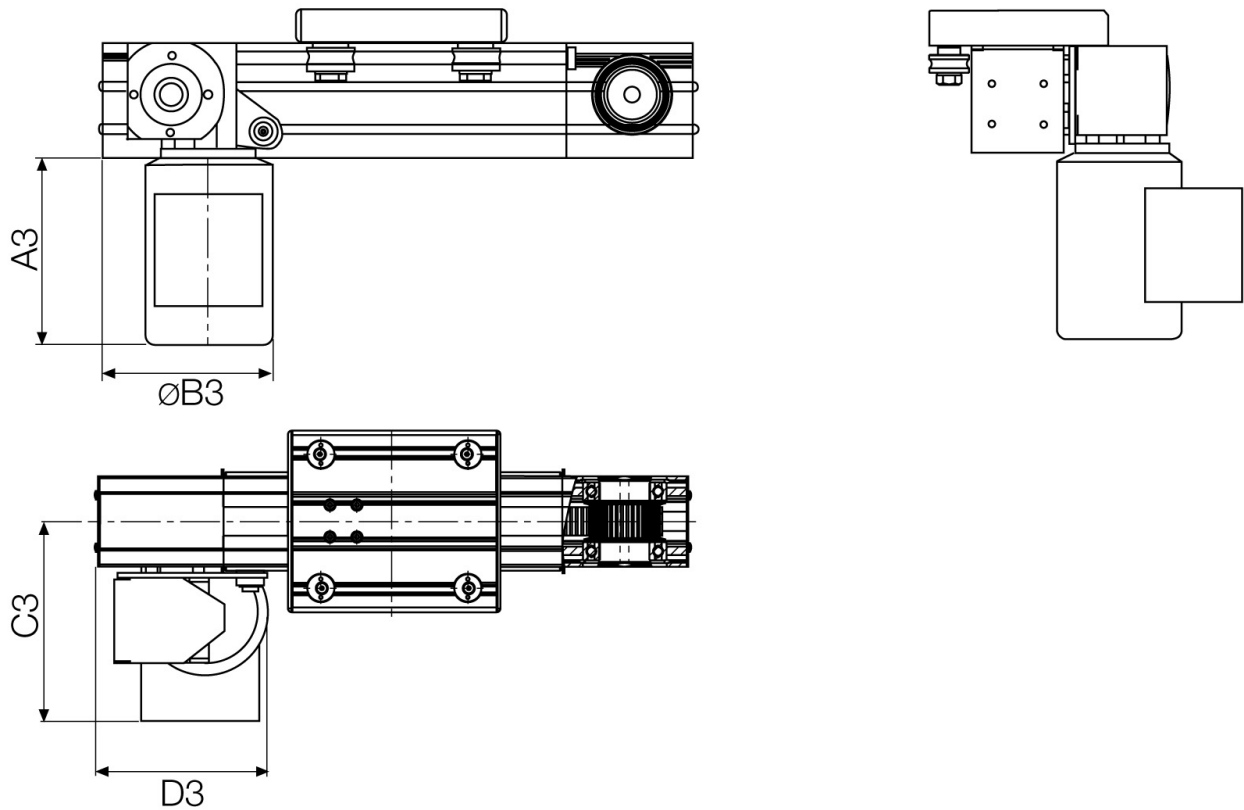

Dimensions	Type of motor		
	56	63	71
A3	170	200	215
ØB3	115	125	140
C3	200	205	215
D3	150	155	160

Drive data	Output torque	Drive power
20 min ⁻¹ – 857 min ⁻¹	10 Nm – 21 Nm	0,07 KW – 1,03 KW

7.3.3. Style AZ 2000

Timing Belt	015MR3
Track: Round guide bars, protected against corrosion and hardened, mounted in AL-profile	–
Slide rails conjunction with AL-profile, adjustable to give zero play	X

7.3.3.1. Technical Details

Travel/revolution		114 mm
Friction coefficient	μ	0.1
Mode of installation		any position
Speed of travel		max. 1,5 m/s
Idling torque	M0	0,35 Nm
Moment of inertia	Ix	29.895 cm ⁴
	Iy	29.895 cm ⁴
Moment of resistance	Wx	11.958 cm ³
	Wy	11.958 cm ³
Weight	m0 ¹⁾	4,2 kg
	m100 ²⁾	0,3 kg
	ms ³⁾	1,5 kg
Effective belt pulley diameter	d ₀	36,30 mm
Timing belt Neoprene with glass cord strengthener		type MR3
Timing belt Neoprene with steel cord strengthener		–
Width of timing belt		15,0 mm

¹⁾ Own weight of drive with length of stroke 0

²⁾ Weight per 100 mm length of stroke

³⁾ Weight of moving mass (carrier)

7.3.3.2. Special features

Motor	X
Proximity switch	X
Wipers	X
Combined lubrication and wiper attachment	X
Enhanced protection against corrosion	X
Covers	–
Carrier with non-standard fixing points	X
Motor connection plate	–

7.3.3.3. Dimensions style AZ 2000

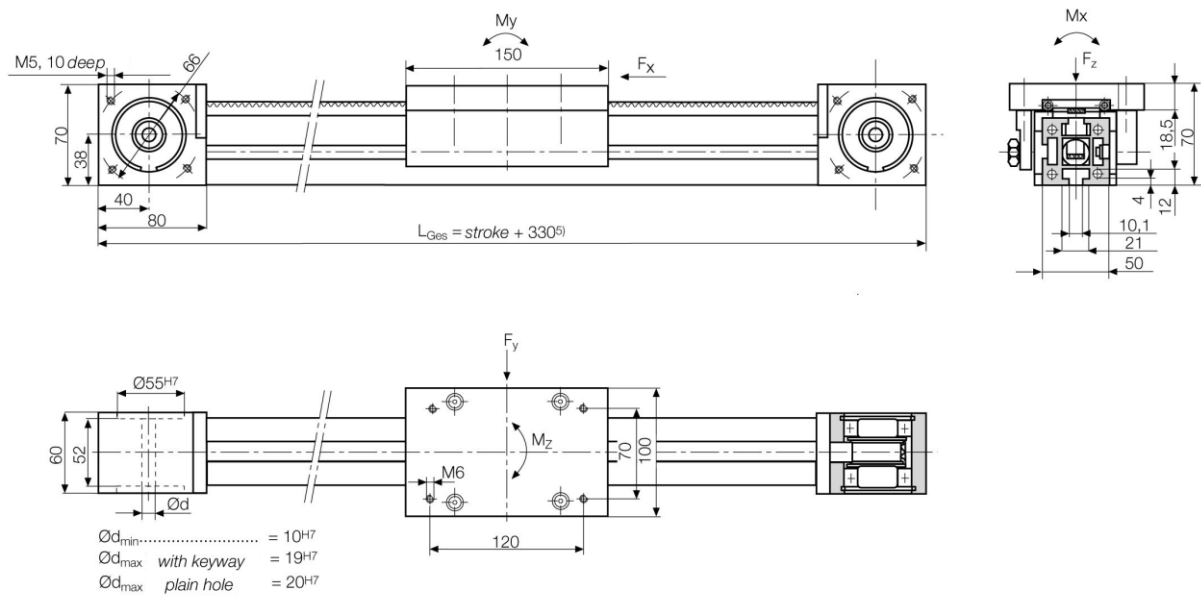

7.3.3.4. Load / Moments

F_x	F_y	F_z	M_x	M_y	M_z
560 N	170 N	90 N	7 Nm	5 Nm	10 Nm

All specifications are based on a running distance of 10.000 km.

7.3.3.5. Moments style AZ 2000

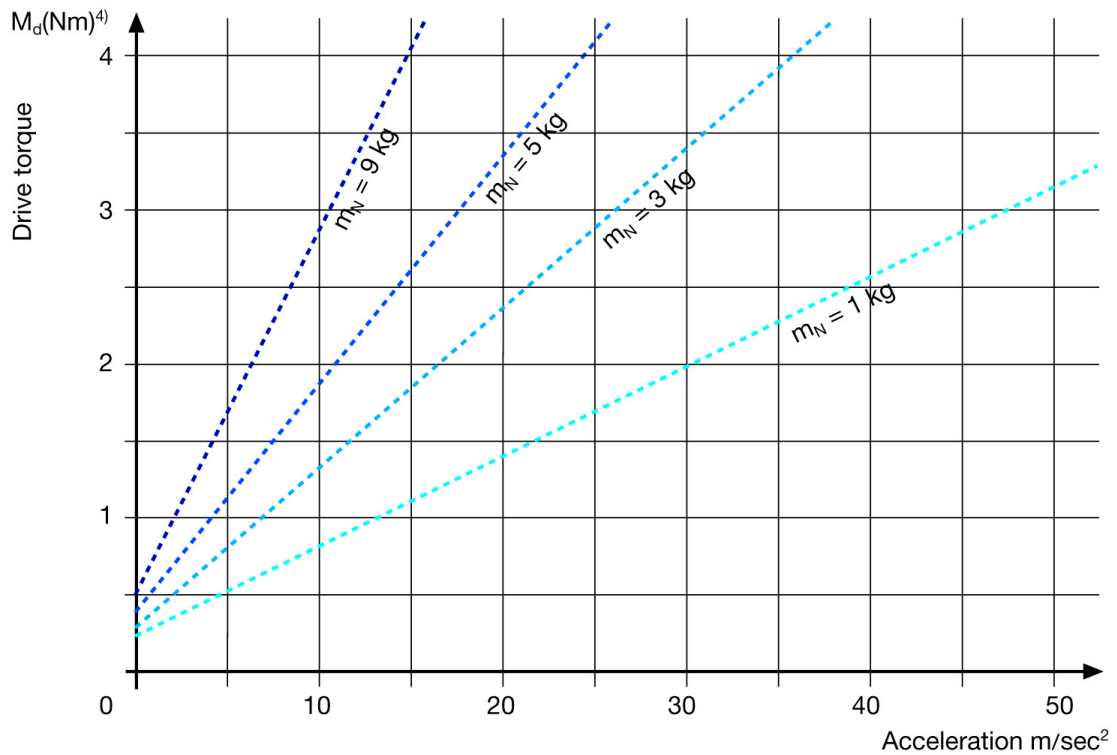

4) Idling torque included

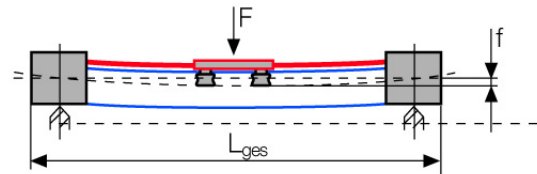
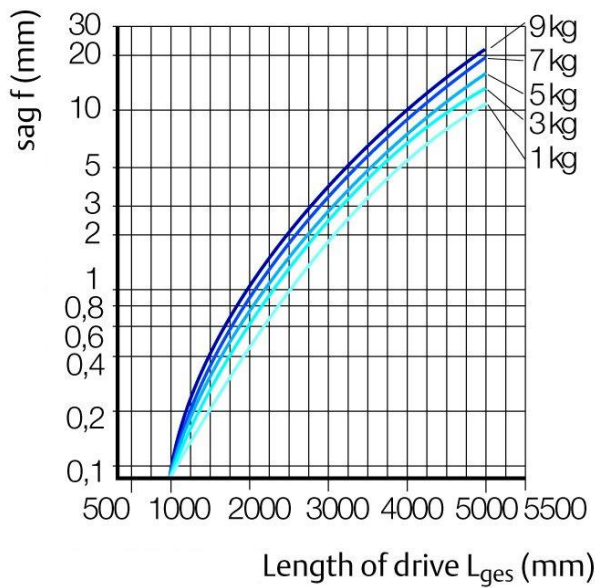

7.3.4. Style AZ 2001

Timing Belt	015MR3
Track: Round guide bars, protected against corrosion and hardened, mounted in AL-profile	X
Slide rails conjunction with AL-profile, adjustable to give zero play	–

7.3.4.1. Technical Details

Travel/revolution		144 mm
Friction coefficient	μ	0.02
Mode of installation		any position
Speed of travel		max. 5 m/s
Idling torque	M0	0,35 Nm
Moment of inertia	Ix	31.5 cm ⁴
	Iy	31.5 cm ⁴
Moment of resistance	Wx	12.8 cm ³
	Wy	12.8 cm ³
Weight	m0 ¹⁾	5,0 kg
	m100 ²⁾	0,65 kg
	ms ³⁾	1,50kg
Effective belt pulley diameter	d ₀	45,83 mm
Timing belt Neoprene with glass cord strengthener		type MR3
Timing belt Neoprene with steel cord strengthener		–
Width of timing belt		15,0 mm

¹⁾ Own weight of drive with length of stroke 0

²⁾ Wight per 100 mm length of stroke

³⁾ Weight of moving mass (carrier)

7.3.4.2. Special features

Motor	X
Proximity switch	X
Wipers	X
Combined lubrication and wiper attachment	X
Enhanced protection against corrosion	X
Covers	X
Carrier with non-standard fixing points	X
Motor connection plate	–

7.3.4.3. Dimensions style AZ 2001

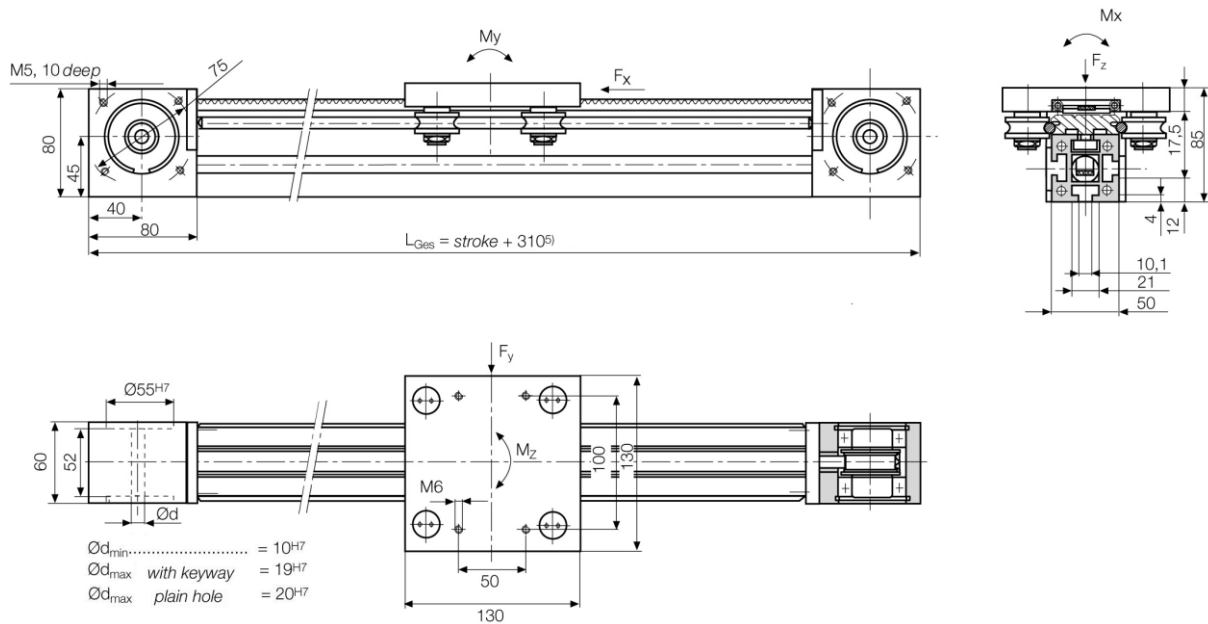

7.3.4.4. Load / Moments

F_x	F_y	F_z	M_x	M_y	M_z
560 N	900 N	1000 N	30 Nm	50 Nm	80 Nm

All specifications are based on a running distance of 10.000 km.

7.3.4.5. Moments style AZ 2001

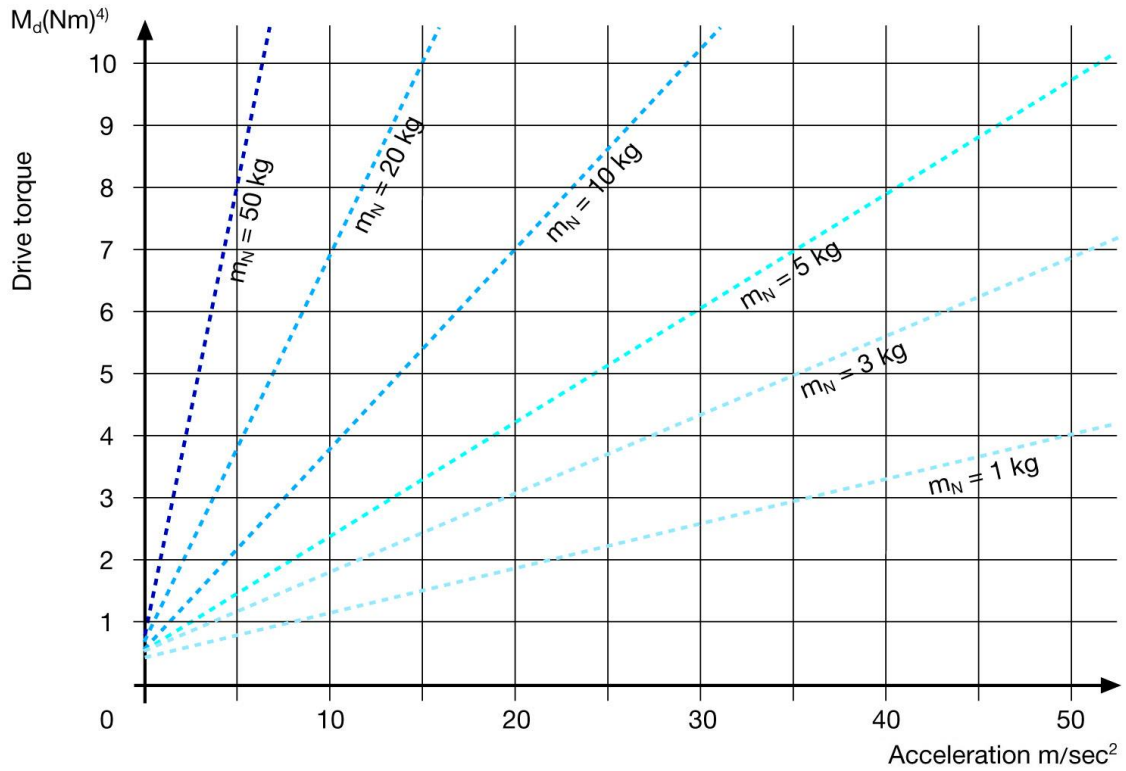

⁴⁾ Idling torque included

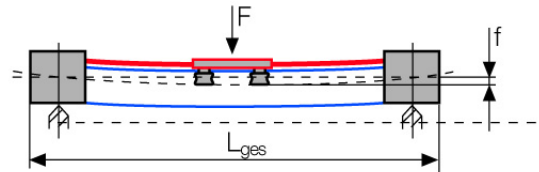
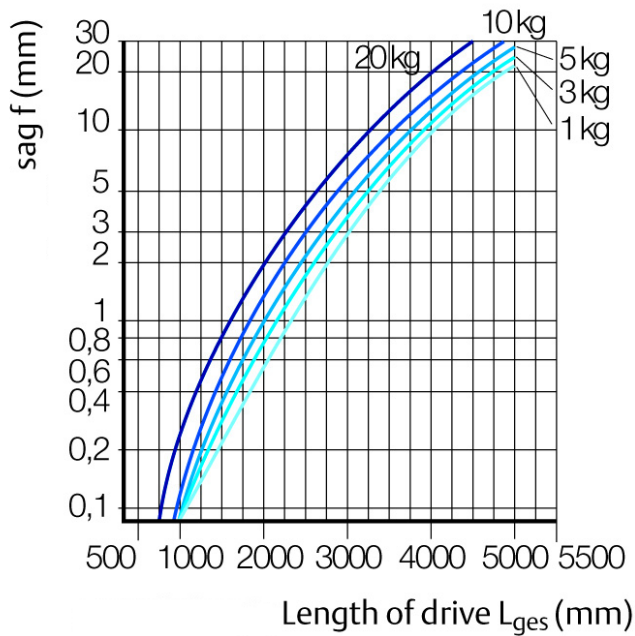

7.3.5. Style AZ 2004

Timing Belt	025MR5
Track: Round guide bars, protected against corrosion and hardened, mounted in AL-profile	X
Slide rails conjunction with AL-profile, adjustable to give zero play	–

7.3.5.1. Technical Details

Travel/revolution		190 mm
Friction coefficient	μ	0.02
Mode of installation		any position
Speed of travel		max. 5 m/s
Idling torque	M0	0,7 Nm
Moment of inertia	Ix	199.956 cm ⁴
	Iy	55.379 m ⁴
Moment of resistance	Wx	39.991 cm ³
	Wy	22.152 cm ³
Weight	m0 ¹⁾	9,0 kg
	m100 ²⁾	0,8 kg
	ms ³⁾	2,3 kg
Effective belt pulley diameter	d ₀	60,48 mm
Timing belt Neoprene with glass cord strengthener		–
Timing belt Neoprene with steel cord strengthener		type MR5
Width of timing belt		25,0 mm

¹⁾ Own weight of drive with length of stroke 0

²⁾ Wight per 100 mm length of stroke

³⁾ Weight of moving mass (carrier)

7.3.5.2. Special features

Motor	X
Proximity switch	X
Wipers	X
Combined lubrication and wiper attachment	X
Enhanced protection against corrosion	X
Covers	X
Carrier with non-standard fixing points	X
Motor connection plate	–

7.3.5.3. Dimensions style AZ 2004

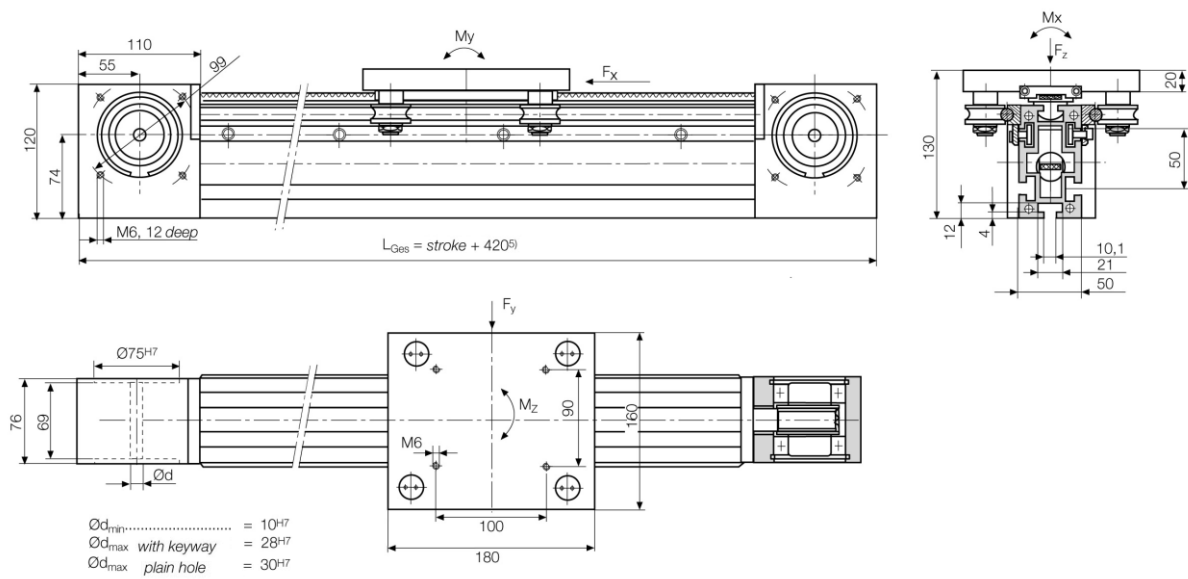

7.3.5.4. Load / Moments

F_x	F_y	F_z	M_x	M_y	M_z
1700 N	2000 N	1200 N	54 Nm	84 Nm	146 Nm

All specifications are based on a running distance of 10.000 km.

7.3.5.5. Moments style AZ 2004

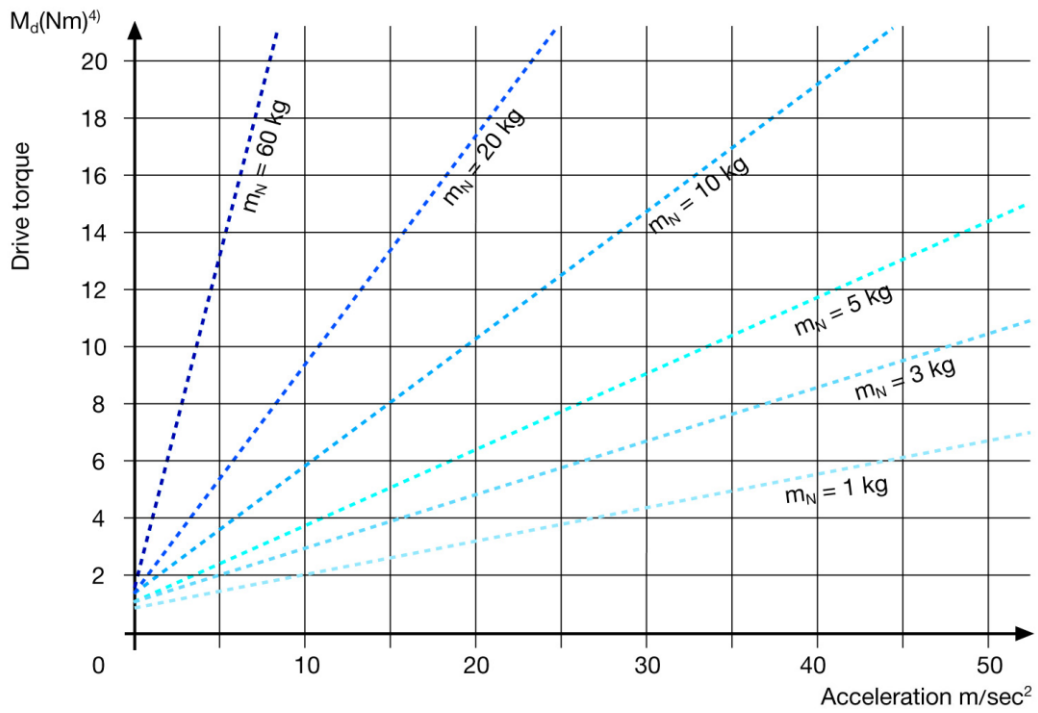

4) Idling torque included

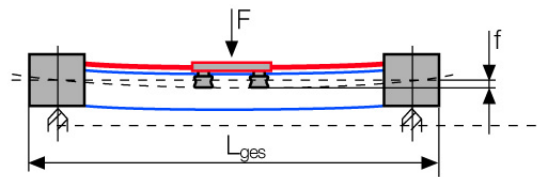
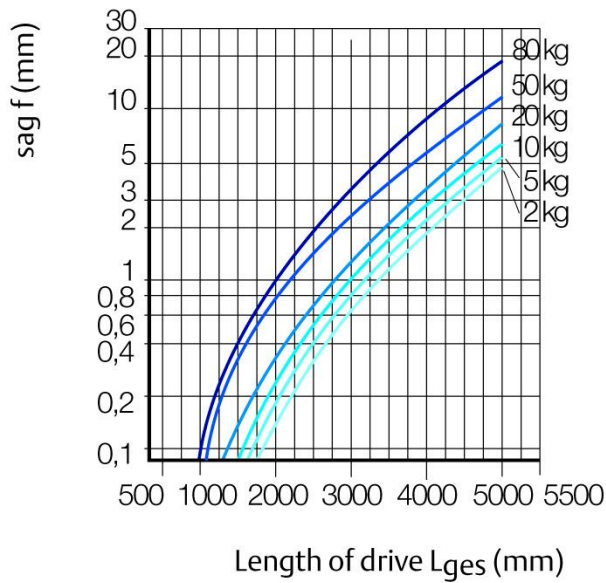

7.3.6. Style AZ 2005

Timing Belt	030MR8
Track: Round guide bars, protected against corrosion and hardened, mounted in AL-profile	X
Slide rails conjunction with AL-profile, adjustable to give zero play	–

7.3.6.1. Technical Details

Travel/revolution		190 mm
Friction coefficient	μ	0.02
Mode of installation		any position
Speed of travel		max. 5 m/s
Idling torque	M0	0,7 Nm
Moment of inertia	Ix	199.956 cm ⁴
	Iy	55.379 m ⁴
Moment of resistance	Wx	39.991 cm ³
	Wy	22.152 cm ³
Weight	m0 ¹⁾	9,0 kg
	m100 ²⁾	0,8 kg
	ms ³⁾	2,3 kg
Effective belt pulley diameter	d ₀	60,48 mm
Timing belt Neoprene with glass cord strengthener		–
Timing belt Neoprene with steel cord strengthener		type MR5
Width of timing belt		25,0 mm

¹⁾ Own weight of drive with length of stroke 0

²⁾ Wight per 100 mm length of stroke

³⁾ Weight of moving mass (carrier)

7.3.6.2. Special features

Motor	X
Proximity switch	X
Wipers	X
Combined lubrication and wiper attachment	X
Enhanced protection against corrosion	X
Covers	X
Carrier with non-standard fixing points	X
Motor connection plate	–

7.3.6.3. Dimensions style AZ 2005

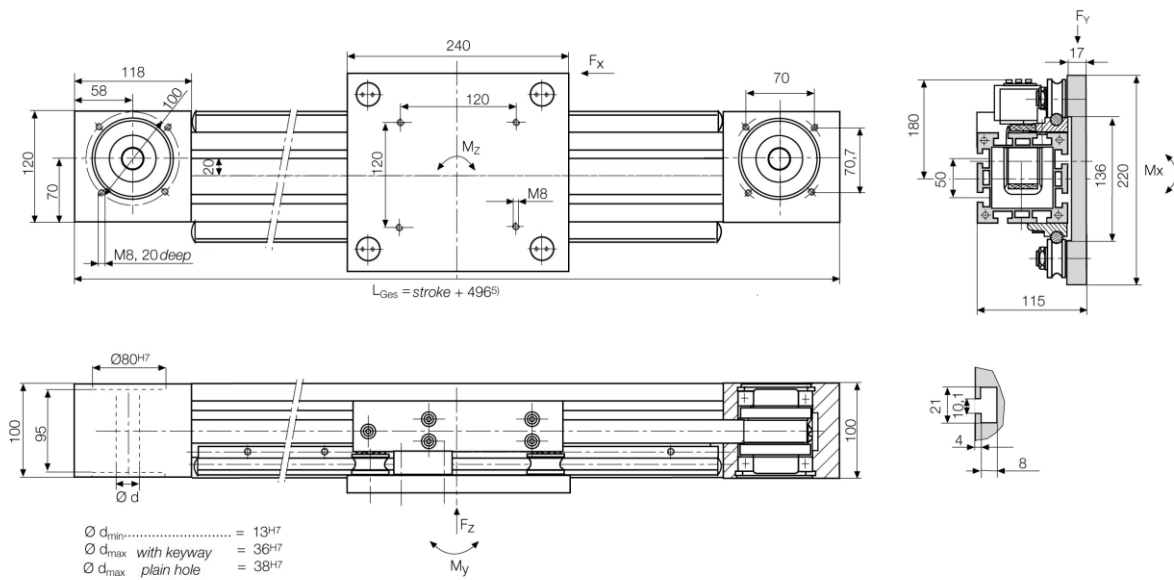

7.3.6.4. Load / Moments

F_x	F_y	F_z	M_x	M_y	M_z
2490 N	2200 N	1200 N	84 Nm	124 Nm	212 Nm

All specifications are based on a running distance of 10.000 km.

7.3.6.5. Moments style AZ 2005

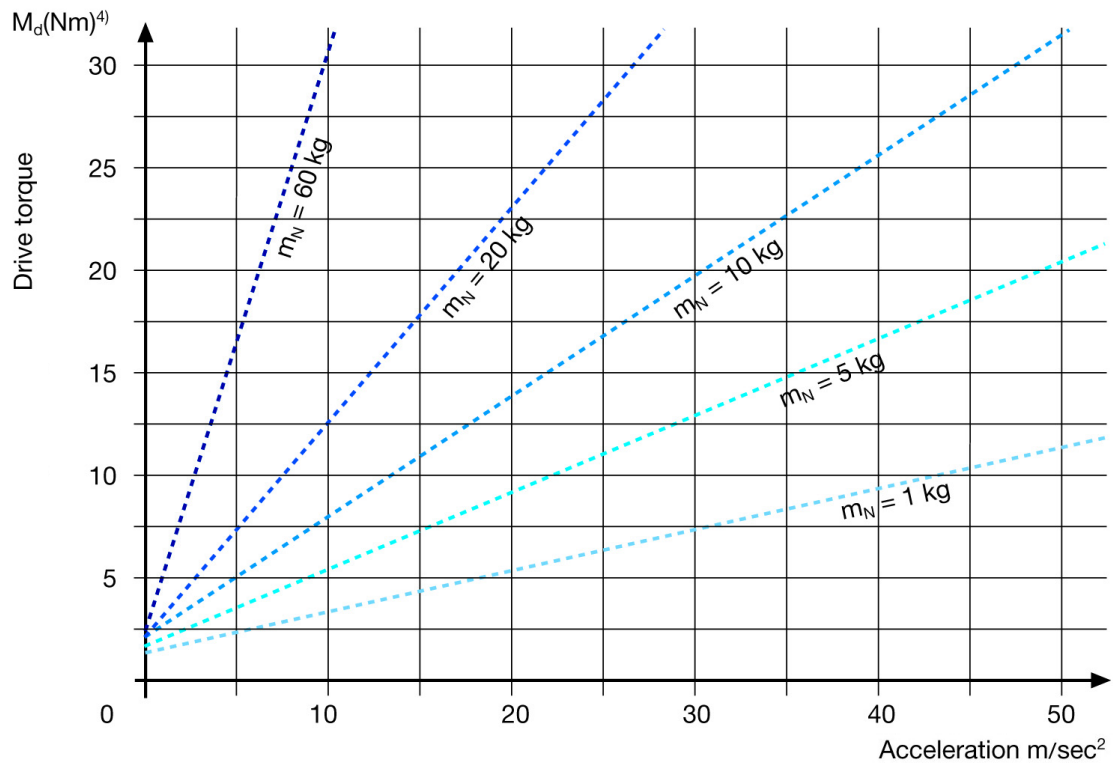

4) Idling torque included

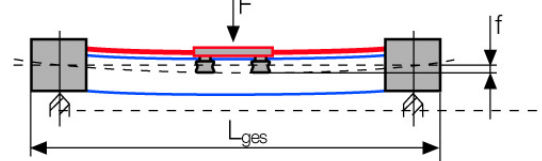
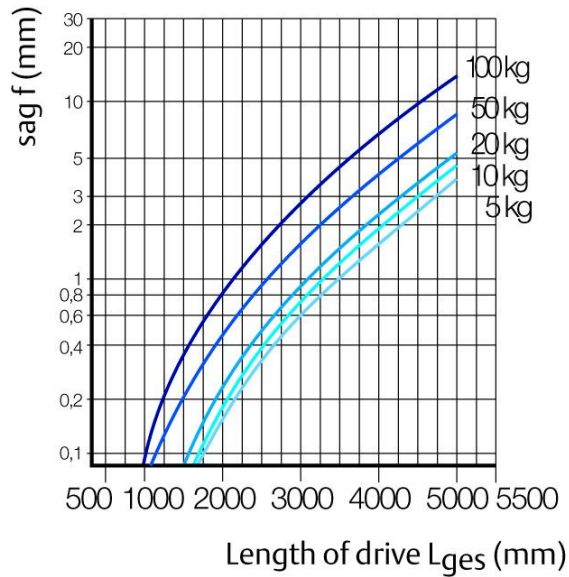

7.4. Accessories

Description	Size		
	AZ 1010	AZ 1040	AZ 2000 – AZ 2005
Slot nut Seel, galvanized	Article No.	Article No.	Article No.
M4	280090003	602550006	
M5	280090020	602550005	602550002
M6		602550008	602620019
M8		602550011	

Further accessories:

- Coupling and shaft assembly
- Proximity and limit switches
- Motor bells
- Overload friction couplings
- Flexible couplings
- Profiled connection pieces
- Connecting plates
- Rotary transducers
- Cable guide chains
- Cover strips for cables and hoses
- End position damping
- Drive spigot, also in combination with rotary transducer drive spigot
- Low play gearing
- Guide units for multi axis systems
- Position indicators
- Hand wheels
- Fixing brackets 90°
- Clamps
- Cover strips



Uhing worldwide

Go straight to your local sales partner.

